

GAME NOS. 932, 933 & 934  
DECEMBER, 1980

# MIDWAY'S

# PAC-MAN

## PARTS AND OPERATING MANUAL

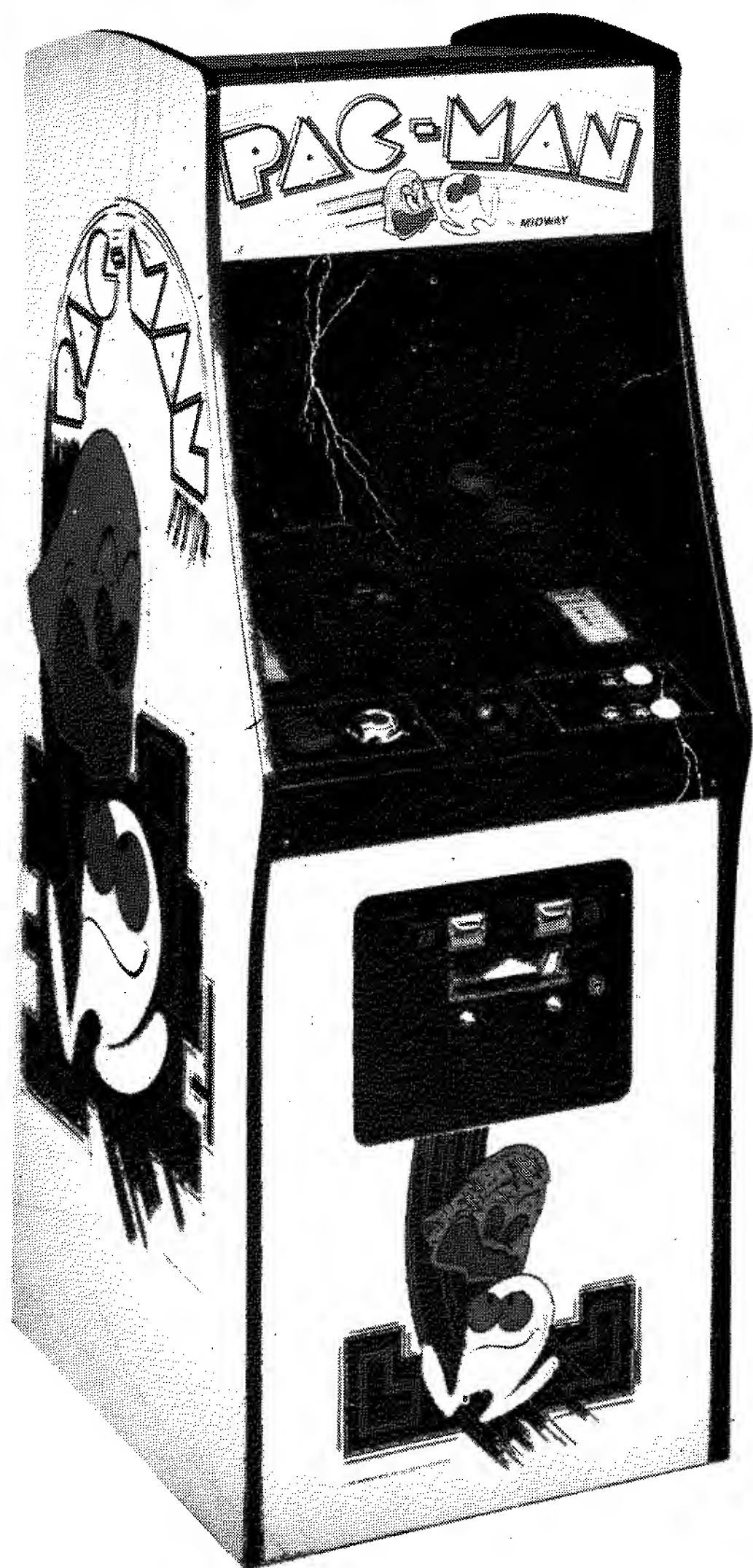

COCKTAIL #933

UP-RIGHT #932

MINI #934



**MIDWAY MFG. CO.**

A BALLY COMPANY

10750 WEST GRAND AVENUE  
FRANKLIN PARK, ILLINOIS 60131  
U.S.A.

PHONE: (312) 451-1360

CABLE ADDRESS: MIDCO

TELEX NO.: 72-1596

# TABLE OF CONTENTS

---

	Page No.
GENERAL INSTRUCTIONS - UP-RIGHT & MINI	1
GENERAL INSTRUCTIONS - COCKTAIL	2—3
MONITOR ADJUSTMENTS - ELECTROHOME	4—6
MONITOR ADJUSTMENTS - WELLS-GARDNER	7—8
SWITCH ADJUSTMENTS	9
NO. 0932 - PAC-MAN UP-RIGHT - PHOTOGRAPH	10—11
INTERIOR ACCESS PICTURE - UP-RIGHT	12—13
NO. 0934 - PAC-MAN MINI - PHOTOGRAPH	14—15
INTERIOR ACCESS PICTURE - MINI	16—17
CONTROL ASSEMBLY - ALL GAME VERSIONS	18—19
PUSH BUTTON ASSEMBLY - UP-RIGHT & MINI	20—21
DOUBLE ENTRY COIN DOOR ASSEMBLY	22—23
NO. 0933 - PAC-MAN COCKTAIL - PHOTOGRAPH	24—26
COCKTAIL ADDITIONAL PARTS LIST	27
SINGLE ENTRY COIN DOOR ASSEMBLY	28—29
TRANSFORMER BOARD ASSEMBLY	30—31
GAME BOARD SCHEMATIC	32
GAME BOARD COMPONENT LAYOUT "A" VERSION	33
GAME BOARD COMPONENT LAYOUT "B" VERSION	34
GAME LOGIC CHIP NUMBER & FUNCTION	35
Z-80 SYNC BUSS CONTROLLER SCHEMATIC	36
Z-80 SYNC BUSS CONTROLLER COMPONENT LAYOUT	37
V-RAM ADDRESSER SCHEMATIC	38
V-RAM ADDRESSER COMPONENT LAYOUT	39
CREDIT MULTIPLIER SCHEMATIC	40
CREDIT MULTIPLIER COMPONENT LAYOUT	41
WIRING DIAGRAM - UP-RIGHT "A" VERSION	42
WIRING DIAGRAM - UP-RIGHT "B" VERSION	43
WIRING DIAGRAM - MINI "A" VERSION	44
WIRING DIAGRAM - MINI "B" VERSION	45
WIRING DIAGRAM - COCKTAIL	46
19" MONITOR SCHEMATIC - WELLS-GARDNER	47
REPLACEMENT PARTS LIST	48—49
19" MONITOR SCHEMATIC - ELECTROHOME	50
REPLACEMENT PARTS LIST	51—54
13" MONITOR SCHEMATIC - ELECTROHOME	55
REPLACEMENT PARTS LIST	56—59
MODIFICATION OF PAC-MAN GAME P.C.B.	60

## WARNING

**THIS GAME MUST BE GROUNDED. FAILURE TO DO SO MAY  
RESULT IN DESTRUCTION TO ELECTRONIC COMPONENTS.**

## GENERAL INSTRUCTIONS FOR "PAC-MAN" UPRIGHT AND MINI

### INSTALLATION

1. Remove shipping cleats located on bottom of cabinet.
2. Install four (4) provided leg levelers to bottom of cabinet and level cabinet.
3. The power is controlled by a switch located on top of the cabinet. Additional taps have been provided on the transformer to compensate for fluctuating line voltage.

### LINE VOLTAGE SAFETY SWITCH

A line voltage safety switch has been provided for your protection. It is located on the right rear side of the cabinet in the back door area. When the back door is removed, it opens the circuit to the line voltage. To restore power (when servicing), pull switch fully out.

### VOLUME CONTROL

The volume control pot is located on the Game Logic Board (P.C. A082-91352-A000). This pot controls the volume of all sounds and may be varied as desired by rotating pot control.

### ADJUSTMENT SWITCHES

Located on Game Logic Board (P.C. A082-91352-A000) and may be adjusted as indicated on separate instruction card in back box area.

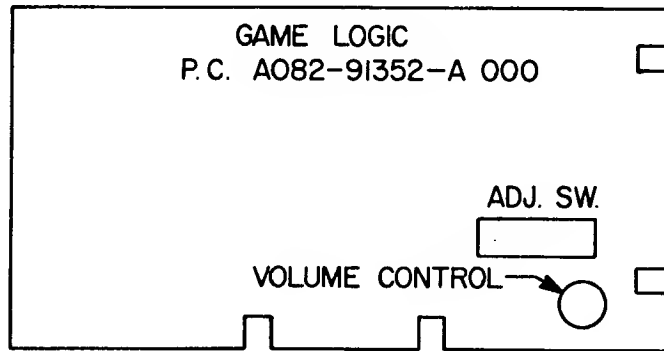

### TO REMOVE CONTROL PANEL AND MONITOR DISPLAY GLASS

1. Open coin door.
2. Release two (2) clamps located below Control Panel on each side of cabinet.
3. Disconnect control panel jack.
4. Remove control panel.
5. Remove monitor display glass.

### CREDIT PUSH BUTTON SWITCH

Located in cash box area and is readily accessible by opening coin door. This switch is provided as a test aid and awards one credit without advancing coin meter.

M051-00932-A003

---

**WARNING:** This equipment Generates, Uses and can Radlate Radio Frequency Energy and if not installed and used in accordance with the Instructions Manual, may cause interference to Radio Communications. As temporarily permitted by Regulation it has not been tested for compliance to Subpart J or Part 15 of FCC Rules, which are designed to provide reasonable protection against such interference. Operation of this equipment in a Residential Area is likely to cause interference in which case the user at his own expense will be required to take whatever measures may be required to correct the interference.

## GENERAL INSTRUCTIONS FOR "PAC-MAN" COCKTAIL TABLE

### INSTALLATION

1. Remove shipping cleats located on bottom of cabinet.
2. Install four (4) provided leg levelers on bottom of cabinet and level cabinet.
3. The power is controlled by a switch located on the bottom of the cabinet. Additional taps have been provided on the transformer to compensate for fluctuating line voltage.

### LINE VOLTAGE SAFETY SWITCH

A line voltage safety switch has been provided for your protection. It is located in the cabinet on the left side of the coin door. When the coin door is opened the circuit to the line voltage is interrupted. To restore power (when servicing), pull switch fully out.

### VOLUME CONTROL

The volume control pot is located on the Game Logic Board (P.C. A082-91352-A/B000). The pot controls the volume of all sounds and may be varied as desired by rotating pot control.

### ADJUSTMENT SWITCHES

Located on Game Logic Board (P.C. A082-91352-A/B000) and may be adjusted as indicated on separate instruction card in back door area.

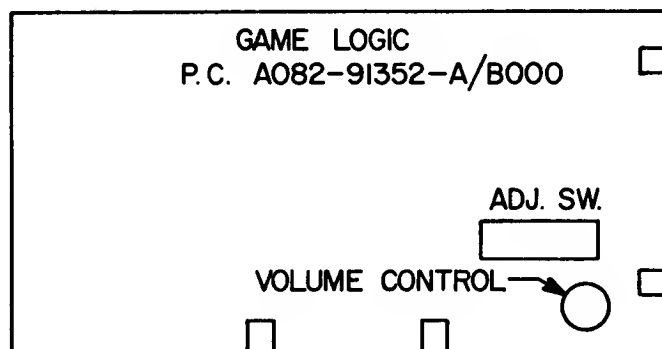

### CREDIT PUSH BUTTON SWITCH

Located to right of cash box and is readily accessible by opening coin door. This switch is provided as a test aid and awards one credit without advancing coin meter.

### TEST SLIDE

Located to right of cash box and is readily accessible by opening coin door. When placed in "ON" position, this switch indicates test mode.

M051-00933-A003

## GAME BOARD TEST

Place test slide switch in "ON" position. If game board is good, the following information will be displayed on the screen:

OK  
Coin Adjustment Setting  
Bonus Adjustment Setting  
Number of PAC-MAN Per Game Setting  
Game Version

## RAM/ROM TEST

If any of the Rams or Roms are faulty, the following information will be displayed on the screen:

### BAD ROM LOCATION CODE

Display	Location
M-Rom-0	6E
M-Rom-1	6F
M-Rom-2	6H
M-Rom-3	6J

### BAD RAM LOCATION CODE

Display	Location
Bad V Ram-0	4K
Bad V Ram-1	4N
Bad C Ram-0	4L
Bad C Ram-1	4P
Bad W Ram-0	4M
Bad W Ram-1	4R

## CONTROL PANEL AND COIN SWITCH TEST

To verify operation of any switch, close switch in question. If switch is operating properly, a game sound will emit when closure is made.

Caution: Be sure to return test switch to game mode when all tests are completed.

## TO SERVICE MONITOR, GAME BOARD AND TRANSFORMER ASSY.

1. Open coin box door and release two (2) clamps indicated on sketch below.
2. Grasp monitor mounting panel at "A" and open as indicated in sketch below.

Caution: Due to the weight of the monitor extreme care must be exercised when opening cabinet for service.

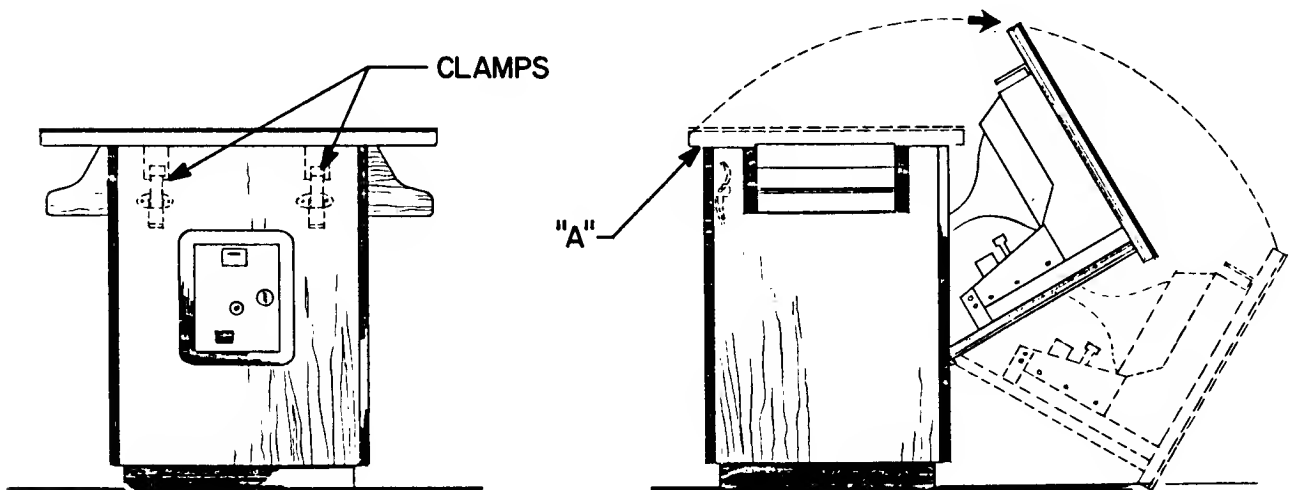

# MONITOR - GENERAL INSTRUCTIONS

## Service Set-Up Procedure

**NOTE:** All monitors are equipped with automatic degaussing coils which effectively demagnetize the picture tube each time the monitor is turned on. The degaussing coils will operate any time the set is turned on after having been off for at least five minutes.

The degaussing effect is confined to the picture tube since the coils are mounted on the ferrous tube shield. Should any part of the chassis or cabinet become magnetized, it will be necessary to degauss the affected area by means of a manual degaussing coil. Move the coil slowly around the CRT face area, then slowly withdraw for a distance of six feet before disconnecting the coil from the AC power supply.

Normally little, if any adjustment should be necessary. However, when a picture tube, yoke or similar component is replaced, preliminary static convergence should be done before attempting purity adjustment, and so on.

Set up should be done in a north/south direction. Horizontal and vertical centering taps should be set to the centre position if a major component has been changed.

### 1.0 Purity

- 1.1 Loosen yoke retaining clamp (figure 2), remove adhesive material fixing wedges to CRT. Remove wedges completely and clean off dried adhesive from picture tube and wedges.
- 1.2 A small quantity of "nail polish" has been used to lock the purity convergence rings in place. This seal must be broken with a sharp tipped instrument before any adjustments are attempted. Some models also use a locking ring at either end of the purity and convergence rings. This must be loosened before adjustments are made. It goes without saying that upon completion of all adjustments, the lock must be reset and/or a dab of paint or nail polish must be re-applied to edge of rings to prevent movement.
- 1.3 Connect an appropriate signal source, eg: Electro-home RGB generator producing a white field plus individual red, green and blue fields.
- 1.4 Bring the long and short purity tab protrusions in line with each other to obtain near-zero magnetic field (figure 4) (In some cases bring the flat and indented tabs together to obtain zero field). Protrusions can then be vertical, horizontal or at any convenient angle to start.
- 1.5 Turn off the green and blue fields and adjust setup controls to produce a red field. (See fig. 3)
- 1.6 Pull the deflection yoke back so that a red band appears in the centre of the screen.
- 1.7 Spread the tabs apart as little as necessary and rotate both rings together to center the red band horizontally on the face of the CRT (approximate). (See Fig. 5)
- 1.8 Slide the yoke towards the bell of the picture tube slowly to obtain a uniform red field (pure in color) across the entire tube face. Juggle back and forth slightly as necessary. Lightly tighten yoke retaining clamp.
- 1.9 Momentarily switch on a cross-hatch signal and rotate yoke to level the pattern on the face of CRT.
- 1.10 Return generator to regain red raster.
- 1.11 Turn off red field and check for pure field for each of the green and blue fields. Reposition yoke if necessary to obtain optimum purity on all fields.
- 1.12 Tighten yoke retaining clamp to prevent yoke shift or rotation. (Do not install wedges at this time.)

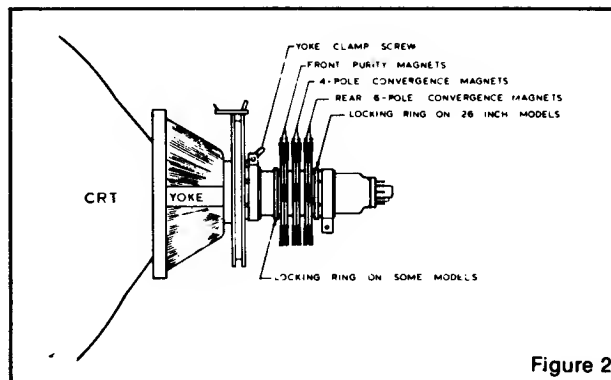

Figure 2

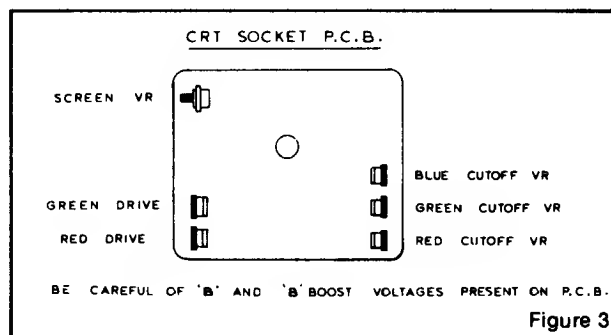

Figure 3

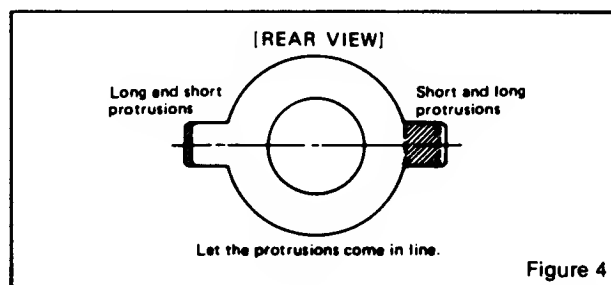

Figure 4

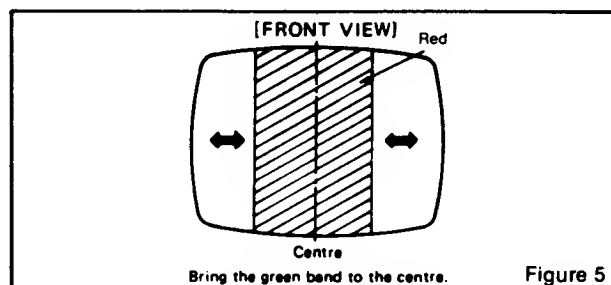

Figure 5

## 2.0 Static and Dynamic Convergence

NOTE: Static convergence is achieved by four magnets located on the neck, nearest the base of the picture tube, Fig. 2. The middle pair of magnetic rings are adjusted to converge the blue and red crosshatch lines. The rear pair of convergence rings (closest to the base of the picture tube) are adjusted to converge the magenta (blue/red) to the green crosshatch lines. Dynamic convergence is achieved by tilting the deflection yoke up-down and left-right.

- 2.1 Ensure that the controls misadjusted during purity setup (screen, cut-off, etc.) are set to give white balance. See 3.0 below.
- 2.2 Switch generator to the crosshatch pattern.
- 2.3 Adjust convergence around the edges of the picture tube by tilting the yoke up-down and left-right, and temporarily install one wedge at the top of the yoke or in a more optimum position. (Figures 8, 9, 10)
- 2.4 Turn off green input and turn on the red and blue input.
- 2.5 Rotate the 4-pole (middle) pair of magnets as a unit to minimize separation of the red and blue crosshatch lines around the center of the screen (Figure 6). Variation of the angle between the tabs adjusts convergence of red and blue. (Tilt yoke as required to converge red and blue at the edges as in 2.3 above.)
- 2.6 Turn on green input to obtain magenta (red/blue) and green crosshatch lines. Rotate the 6-pole (rear) pair of magnets as a unit to minimize separation of the magenta and green lines (figure 7). Vary angle between the two tabs and further rotate as a unit to finalize.
- 2.7 When convergence of 3 colors is optimized (static in center and dynamic around edges) apply stripe of paint or nail polish to convergence magnet rings to prevent movement. If applicable, tighten locking ring carefully.
- 2.8 Remove temporary wedge from yoke. Tilt yoke in up-down and left-right direction for best circumference convergence and install 3 wedges. (It is best to use 3 new wedges since they have adhesive backing. Simply pull off tape, slide wedge in place and press outer flap down firmly. For more permanency apply small quantity of silastic or similar material at junction of wedges and picture tube. Do not disturb while material is setting. (Order wedges by part number 39-1233-01).

## 3.0 White Balance (Grey Scale Tracking)

Refer to figure 3. Do the following in subdued light:

- 3.1 Note this adjustment can be accomplished with no signal connected; eg: input connector open or if a signal generator is connected, switch off all 3 inputs at the generator.
- 3.2 Set red and green drive controls to their mechanical center and turn the common G2 screen control and 3 cut-off controls to minimum (fully counterclockwise).
- 3.3 Slowly turn up G2 screen control until the first faint color appears, then back off to edge of visibility. Do not touch the associated cut-off control - it should stay fully CCW for the remaining set-up.
- 3.4 Slowly turn up the other two color cut-off controls in turn to match the first. This should result in the faintest grey.
- 3.5 Turn on the signal generator with all 3 inputs on. (a crosshatch pattern would be appropriate).

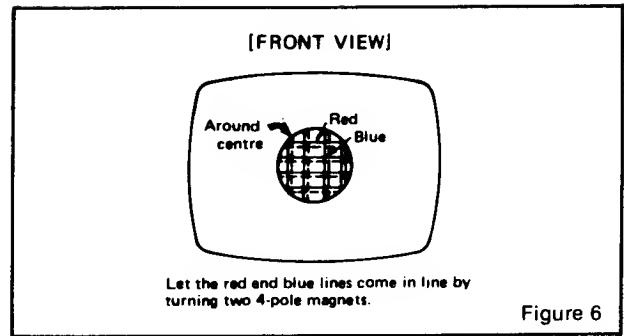

Figure 6

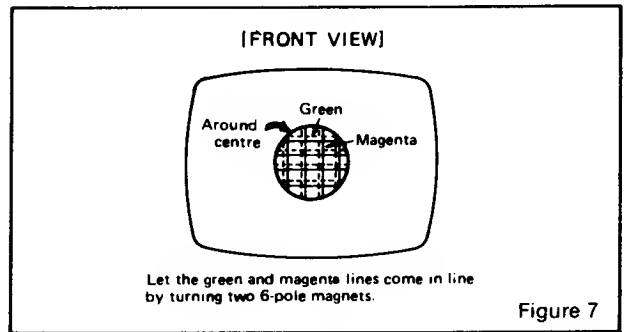

Figure 7

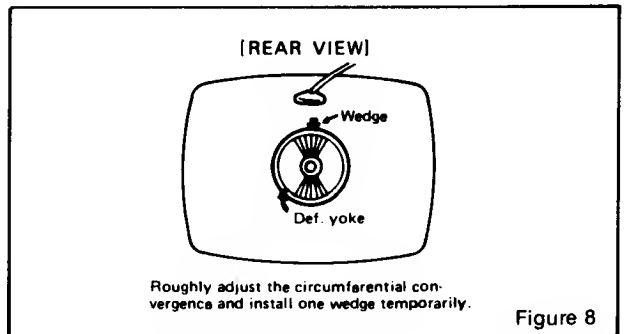

Figure 8

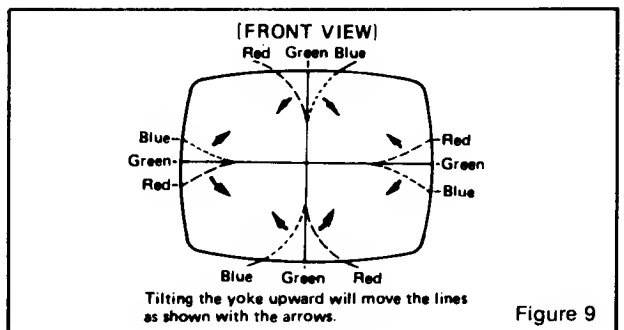

Figure 9

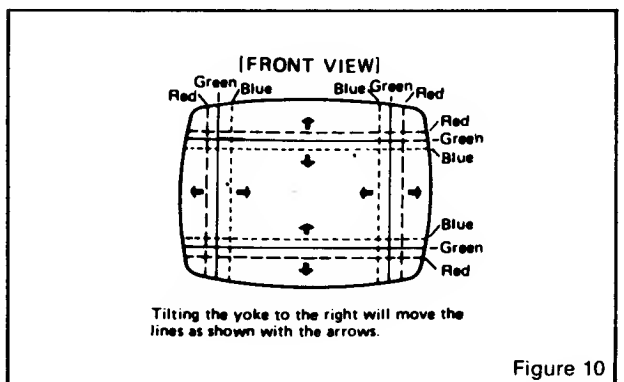

Figure 10

- 3.6 Adjust the red and green drive controls for "neutral white" on high white picture areas. Generally these controls will be left at mech. centre.
- 3.7 Note: When monitor is re-connected with the game the screen control (G2) may require a slight adjustment to obtain proper black level. (the black portion of picture just extinguished).

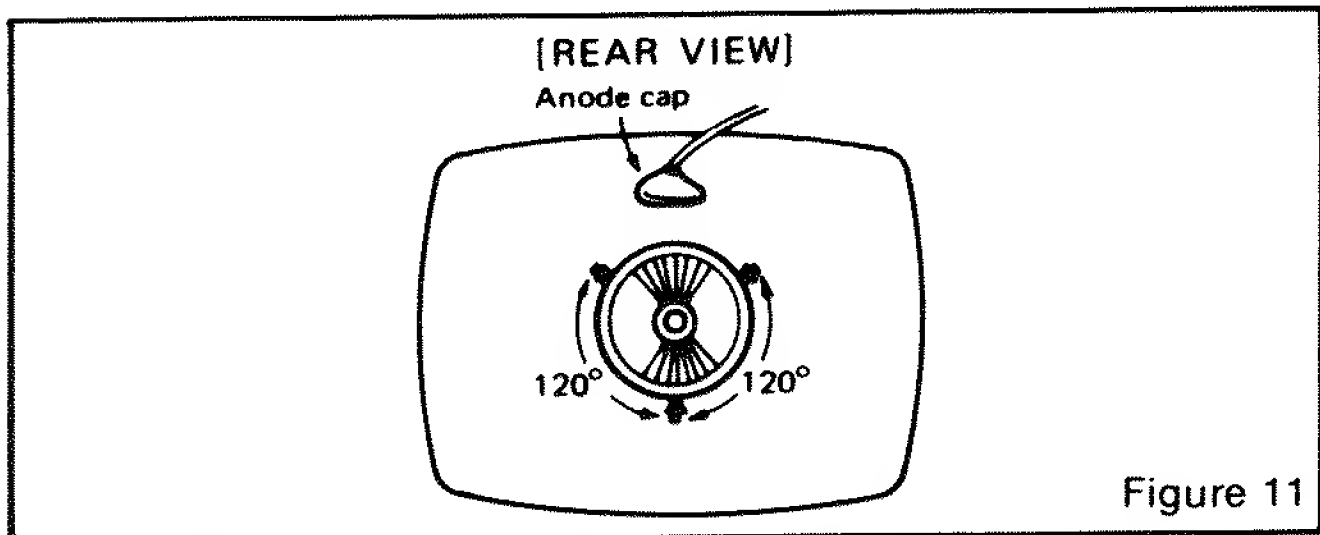

Figure 11

#### 4.0 Power Supply

The regulated +B1 control (R909) has been factory adjusted and normally requires no adjustment. However, if any repairs have been made to the chassis it is recommended that this adjustment should be made.

- Allow 5 minutes to warm up.
- No signal applied.
- Connect an accurate D.C. voltmeter to TP-91 or the emitter of X04 power regulator transistor.
- Adjust R909 for 120V. (See fig. 1)

Note:

Should +B1 control be set too high, it may cause possible component damage. Use an accurate D.C. voltmeter to set B1 (B+).

#### 5.0 Focus

Adjust focus control for best overall definition and picture detail an average signal applied. (Highlights should be favoured.)

#### 6.0 Color Service Generator for G07 Monitor

Electrohome has developed a color service generator that is specifically designed for use with the G07 color data monitor. It provides the monitor with both horizontal and vertical sync, as well as the following test patterns:

- Fine cross-hatch pattern
- Broad bar cross-hatch pattern
- Complete field

Three color selection switches, red, green and blue, provide the ability to display the above patterns in the three primary colors as well as the three secondary colors.

This product may be ordered from:

Contracts Marketing  
ELECTROHOME Electronics

809 Wellington St. North

Kitchener, Ontario

Canada N2G 4J6

Telephone: (519) 744-7111, Ext. 567

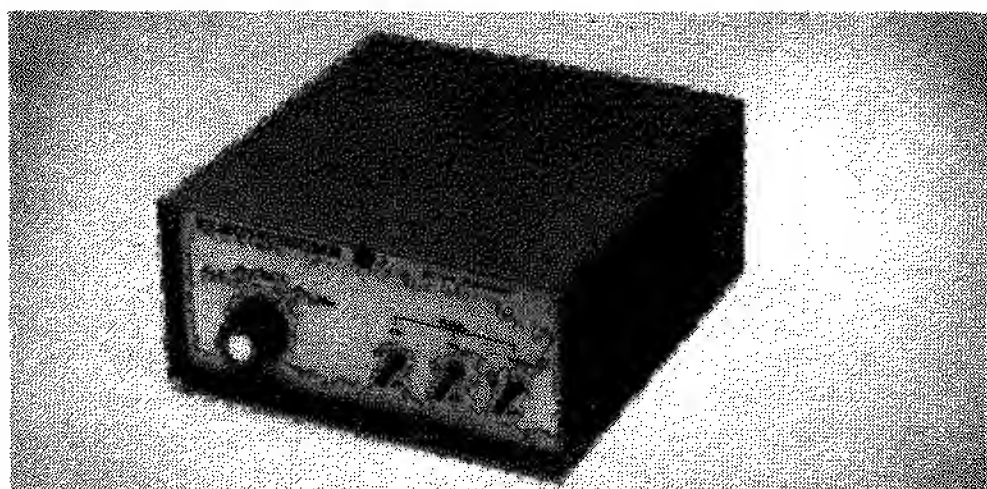

#### 7.0 X-Ray Emission Check

- Assure the power supply B1 is properly adjusted to 120V DC. See Item 4.0 (page 8)
- Assure that the anode voltage does not exceed max. as per Item 2.0 page 4.
- Assure that the high voltage hold down circuit is operating correctly. Use the following procedure.

- Increase the B1 greater than 138.5V by shorting collector/emitter of the power regulator, X04.
- Observe that the anode voltage (EHT) goes to 0. If the EHT does not go to 0, a fault must be located and repaired.
- Remove short and set should return to normal operation. (Note, after the short is removed some monitors may not restart. In this case, remove power from monitor momentarily and normal operation will be restored.

Note:

The protector circuit consists of the components shown below in Fig. 13 with a circuit description.

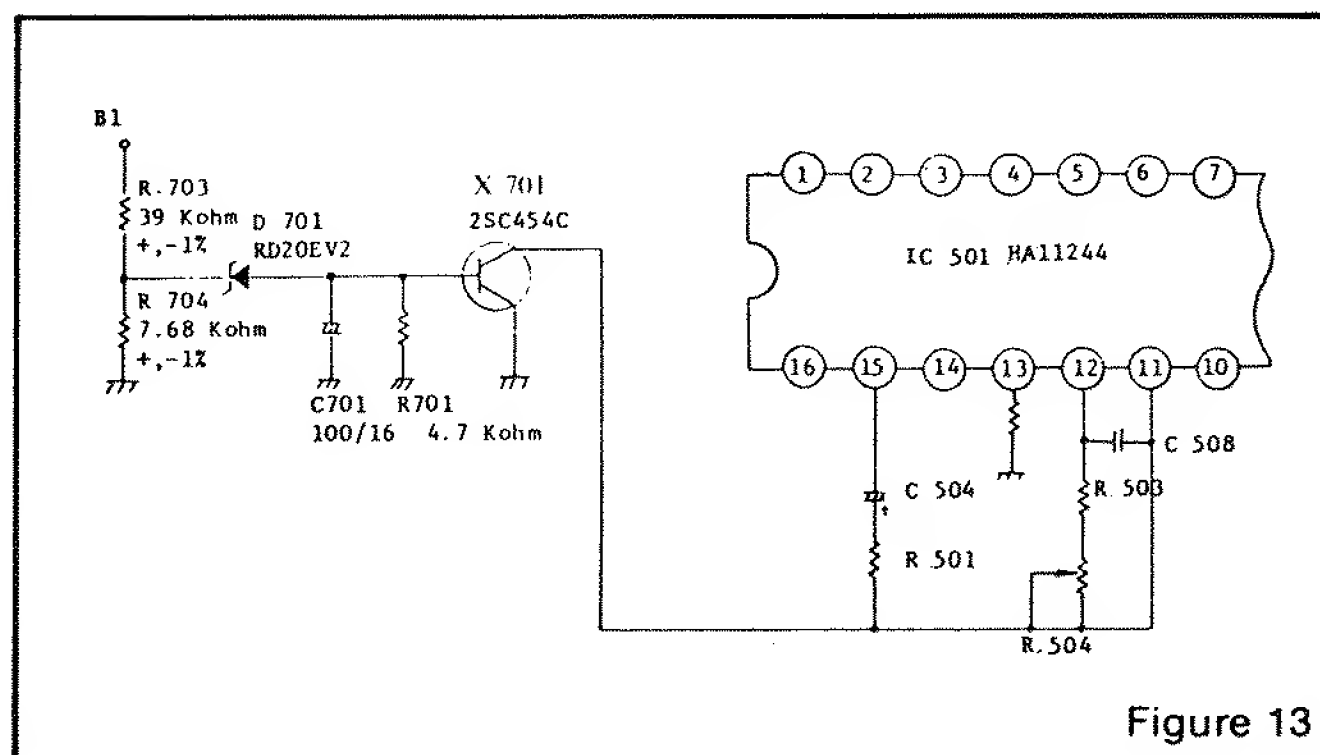

Figure 13

#### 8.0 Circuit Diagram and Description of High Voltage Hold Down or Safety Circuit

- Circuit Diagram of High Voltage Hold Down Circuit.
- Operation of High Voltage Hold Down Circuit.

The high voltage hold-down circuit protects the high voltage circuit from dangerous voltage with short circuiting between emitter and collector of power regulating transistor.

The base voltage of X701 is increased when the B1 voltage is increased more than 138.5 V DC.

When the base of X701 is increased, a short is produced by X701 between pin 11 and ground of IC 501, shutting down the horizontal osc. and high voltage.



# INSTALLATION AND SERVICE INSTRUCTIONS

## COLOR PURITY AND VERTICAL CENTERING ADJUSTMENT

For best results, it is recommended that the purity adjustment be made in the final monitor location. If the monitor will be moved, perform this adjustment with it facing west or east. The monitor must have been operating 15 minutes prior to this procedure and the faceplate of the CRT must be at room temperature.

The monitor is equipped with an automatic degaussing circuit. However, if the CRT shadow mask has become excessively magnetized, it may be necessary to degauss it with manual coil. Do not switch the coil OFF while the raster shows any effect from the coil.

Purity Magnets are used for Color Purity and V Centering Adjustment.

Purity Adjustment procedure is as follows.

1. Remove R-G-B signal from monitor.
2. Turn Green Cut off Control (VR404) on the Neck Board fully CCW.  
Turn Red and Blue Cut off Control (VR405) fully CW.
3. Pull the Deflection Yoke backward so that the Magenta belt will appear. (See Fig. 4)
4. Move the two Purity Magnets and bring the Magenta belt to the mechanical center of the screen (See Fig. 5) The vertical center position should be set VRS to  $-5/64$ " ( $-2$  mm) as shown in Fig. 6.  
Insert service tip "N" on Neck circuit board to "S" on Vert./Horiz. circuit board (See Fig. 13). To check, use the Green raster at low intensity. Be sure to return the service tips to their original positions for the next check.
5. Push the Deflection Yoke forward gradually and fix it at the place where the Magenta screen becomes uniform throughout.
6. Turn Cut off Control, and Drive Control and confirm that each color is uniform.
7. If the color is not uniform, re-adjust it moving Purity Magnets slightly.
8. Move a pair of Purity Magnets at the same time (do not change the angle of the pair), and adjust the vert. center to center of screen.
9. Obtain the three colors and confirm whether white uniformity is balanced.
10. Insert the temporary wedge as shown in Fig. 5 and adjust the angle of Deflection Yoke.

## STATIC CONVERGENCE ADJUSTMENT

A recently developed Deflection Yoke and Electron Guns construction has been used on this equipment in combination with In-Line Guns and Black Stripe Screen to make a barrel-type magnetic-field distribution for vertical deflection and a pin-cushion-type magnetic field for horizontal deflection with which a self-converging system can be obtained. This type is different from conventional unity-magnetic field distribution type deflection yoke. 4-Pole Magnets and 6-Pole Magnets are

employed for static convergence instead of a Convergence Yoke.

1. A cross hatch signal should be connected to the monitor.
2. A pair of 4-Pole Convergence Magnets are provided and adjusted to converge the blue and red beams. When the Pole opens to the left and right  $45^\circ$  symmetrically, the magnetic field maximizes. Red and blue beams move to the left and right oppositely (See Fig. 7-a and 7-b). Variation of the angle between the tabs adjusts the convergence of red and blue vertical lines.  
When the both 4-Pole Convergence Magnet Tabs are rotated as a pair, the convergence of the red and blue horizontal lines is adjusted.
3. A pair of 6-Pole Convergence Magnets are also provided and adjusted to converge the magenta (red + blue) to green beams.  
When the Pole opens to the left and right  $30^\circ$  symmetrically, the magnetic field is maximized. Red and blue beams both move to the left and right (See Fig. 8-c and 8-d).  
Variation of the opening angle adjusts the convergence of magenta to green vertical lines. When both 6-Pole Convergence Magnet Tabs are rotated as a pair the convergence of magenta to green horizontal lines is adjusted.

## PRECISE ADJUSTMENT OF DYNAMIC CONVERGENCE (See Fig. 10 and 11)

1. Feed a cross hatch signal to the monitor.
2. Insert the temporary wedge and fix Deflection Yoke so as to obtain the best circumference convergence (See Fig. 10 and 11).

NOTE:

The temporary wedges may need to be moved during adjustments.

4. Insert three rubber wedges to the position as shown in Fig. 9 to obtain the best circumference convergence.

NOTE:

- 1) Tilting the angle of the yoke up and down adjusts the crossover of both vertical and horizontal red and blue lines. See Fig. 10 (a) and (b).
- 2) Tilting the angle of the yoke sideways adjusts the parallel convergence of both horizontal and vertical lines at the edges of the screen. See Fig. 11-a and b.
- 3) Use three rubber wedges (thick and thin rubber wedges are used for a purpose).
- 4) The angle of each rubber wedges are shown in Fig. 9.
- 5) After three rubber wedges have been inserted, pull out the temporary wedge.
- 6) Fix the rubber wedges with chloroprene rubber adhesive.

# INSTALLATION AND SERVICE INSTRUCTIONS

## BLACK AND WHITE TRACKING (With R/G.B. inputs grounded)

1. Set Black Level Control (VR201) to mid point.
2. Set Red and Blue Drive Controls (VR401 & VR402) to their mechanical center.
3. Set the G2 Screen Control (VR406) and the 3 Cut-off Controls (VR403, VR404, & VR405) to minimum

(CCW).

4. Slowly turn up G2 screen control until the first faint color appears.
5. Slowly turn up the other two color cut-off controls in turn to match the first.
6. Remove ground from R/G/B/ inputs. Adjust Red and Blue Drive Controls (VR401 & VR402) for white screen.

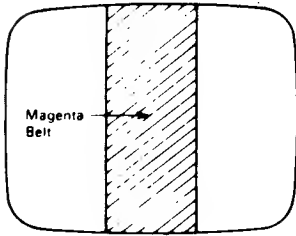

FIGURE 4

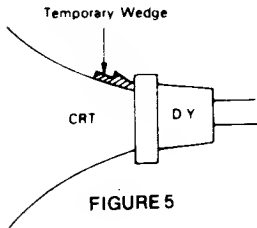

FIGURE 5

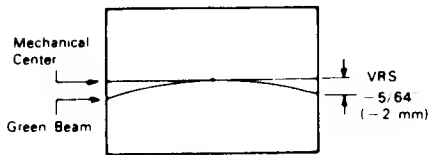
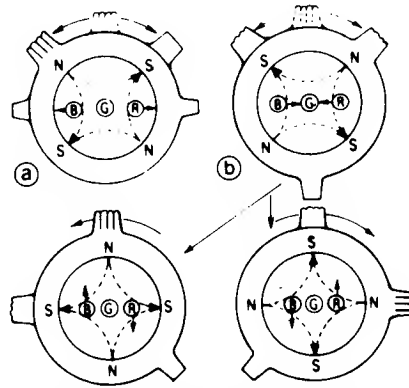
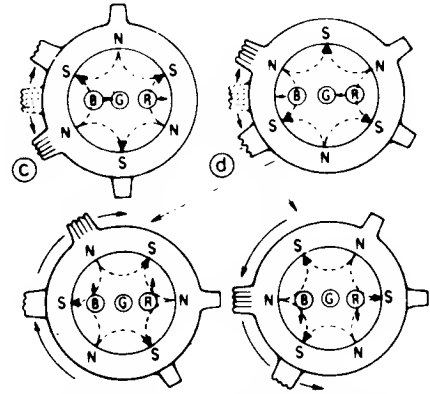

FIGURE 6



4-Pole Magnets and the Movement of Beams

FIGURE 7



6-Pole Magnets and the Movement of Beams

FIGURE 8

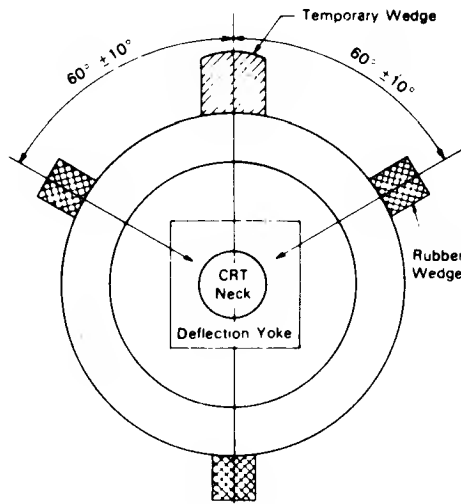
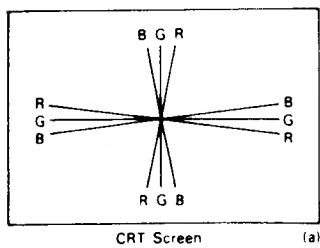
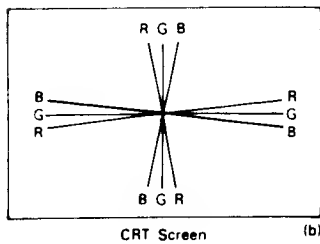

FIGURE 9



CRT Screen (a)



CRT Screen (b)

FIGURE 10

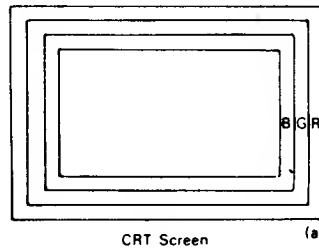
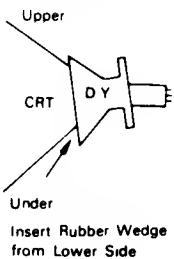
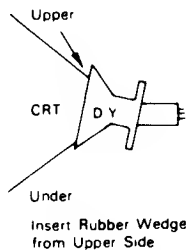

CRT Screen (a)

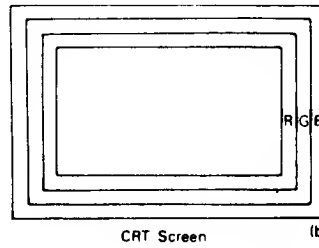

CRT Screen (b)

FIGURE 11

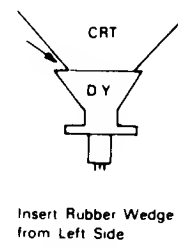

Insert Rubber Wedge from Left Side

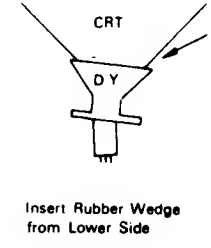

Insert Rubber Wedge from Lower Side

---

**METHOD OF PLAY**

---

SW. #1	SW. #2		
OFF	ON	1 COIN	1 PLAY
ON	OFF	1 COIN	2 PLAY
OFF	OFF	2 COINS	1 PLAY
ON	ON		FREEPLAY

---

**NUMBER OF PACKMEN PER GAME**

---

SW. #3	SW. #4	
ON	ON	1 PACKMAN
OFF	ON	2 PACKMEN
ON	OFF	3 PACKMEN
OFF	OFF	5 PACKMEN

---

**BONUS PACKMEN**

---

SW. #5	SW. #6	
ON	ON	BONUS PACKMAN AT 10,000
OFF	ON	BONUS PACKMAN AT 15,000
ON	OFF	BONUS PACKMAN AT 20,000
OFF	OFF	NO BONUS

---

SW. #7	SW. #8	
OFF	OFF	PLAY MODE
ON	OFF	RACK TEST
OFF	ON	LOCKS PICTURE

---

M051-00932-A035

ELECTRICAL BULLETIN: FOR ALL APPARATUS COVERED BY THE CANADIAN STANDARDS ASSOCIATION (CSA) STANDARD C22.2 NO. 1, WHICH EMPLOYS A SUPPLY CORD TERMINATED WITH A POLARIZED 2-PRONG ATTACHMENT PLUG.

CAUTION: TO PREVENT ELECTRIC SHOCK DO NOT USE THIS (POLARIZED) PLUG WITH AN EXTENSION CORD, RECEPTACLE OR OTHER OUTLET UNLESS THE BLADES CAN BE FULLY INSERTED TO PREVENT BLADE EXPOSURE.

ATTENTION: POUR PREVENIR LES CHOCS ELECTRIQUES NE PAS UTILISER CETTE FICHE POLARISEE AVEC UN PROLONGATEUR. UNE PRISE DE COURANT OU UNE AUTRE SORTIE DE COURANT, SAUF SI LES LAMES PEUVENT ETRE INSEREES A FOND SANS EN LAISSER AUCUNE PARTIE A DECOUVERT.

NO. 932 - PAC-MAN UP-RIGHT - PHOTOGRAPH

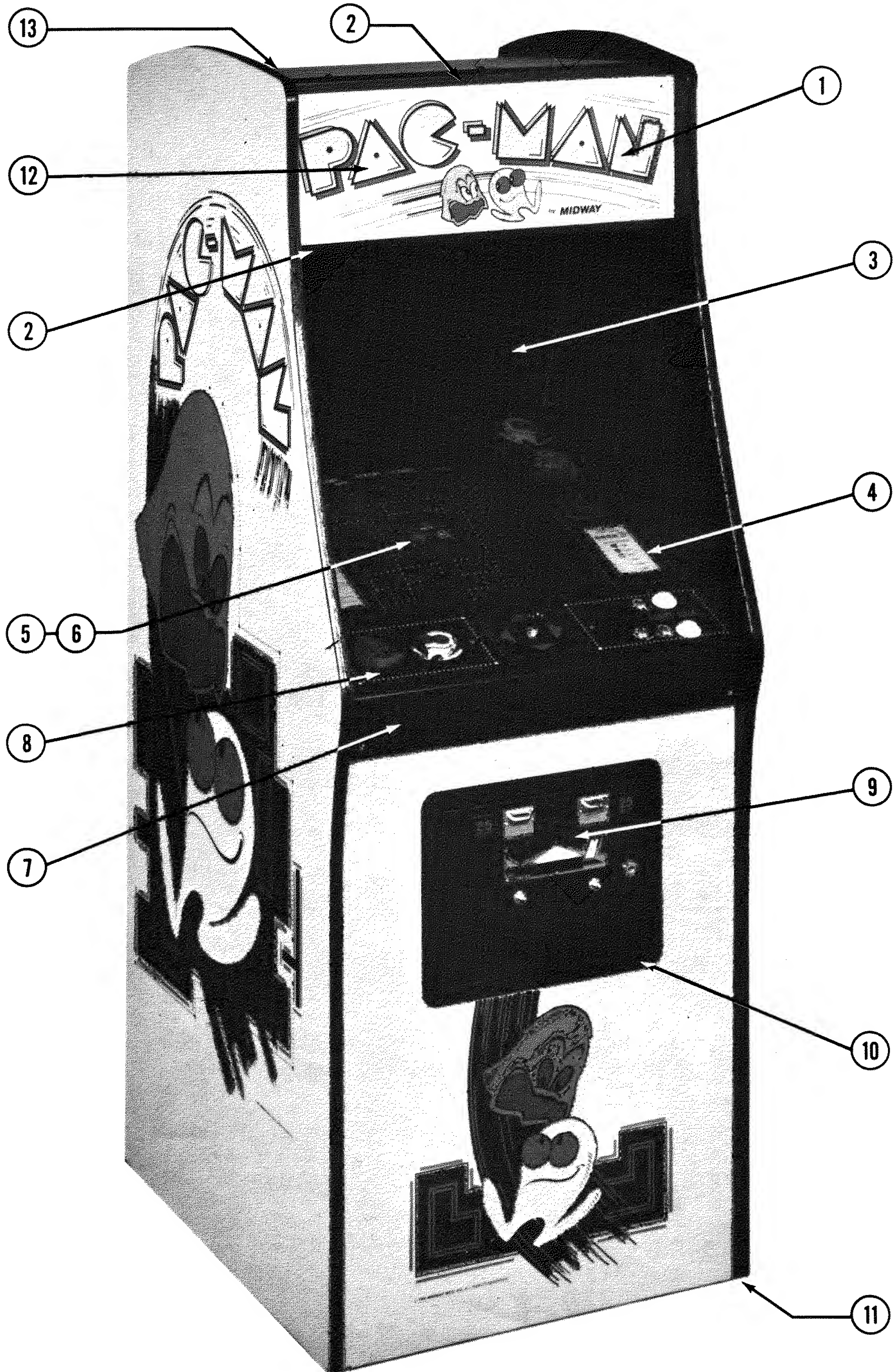

NO. 932 - PAC-MAN UP-RIGHT - PHOTOGRAPH  
**ORDER BY PART NUMBER ONLY**

ITEM	PART NO	DESCRIPTION
1	0932-00901-00XF	UPPER DECORATIVE PLEX—23'' x 9-1/16'' x 3/16''
2	0866-00103-00XF	PLEXI RETAINING BRKT. (2 REQ'D.)
	0017-00101-0066	#10 x 5/8 PHIL. PAN HD. SCREW (6 REQ'D.)
3	0017-00009-0393	BLACK SPEAKER GRILL W/4, 1-1/2'' SCREWS
	0017-00003-0187	6'' x 9'' SPEAKER 8 OHM, 9W.
4	0932-00900-00XF	MAIN DISPLAY GLASS - 23'' x 16-3/8'' x 3/16''
	M052-00050-0005	FOAM TAPE - 1/4 x 23'' LG.
5	A866-00064-0000	T.V. BEZEL & PLEXI ASSY.
6	0017-00003-0339	19'' COLOR MONITOR & CHASSIS W/YOKE - ELECTROHOME
7	0932-00100-00XF	CONTROL SHELF OVERLAY
	0017-00101-0639	#8-32 x 1-1/4 CARRIAGE BOLT (6 REQ'D.)
	0017-00104-0022	STL. FLAT WASHER (6 REQ'D.)
	0017-00103-0061	#8-32 HEX NUT W/SEMS (6 REQ'D.)
	0017-00101-0775	#6 x 1/2 PHIL. PAN HD. SCR. (2 REQ'D.)
8	0932-00903-0000	DECORATIVE CONTROL PANEL
9	A090-00076-02BK	DOUBLE ENTRY COIN DOOR ASSY.
10	0090-00002-02BK	COIN DOOR FRAME
11	0017-00102-0048	3/8-16 x 2'' LEG LEVELER (4 REQ'D.)
	0017-00103-0026	3/8-16 HEX NUT (4 REQ'D.)
12	A866-00068-0000	DISPLAY LAMP BRKT. ASSY. (2 REQ'D.) LOCATED BEHIND ITEM # 1
	0866-00113-0000	SOCKET MTG. BRKT. (2 REQ'D)
	0017-00003-0135	LAMP SOCKET (2 REQ'D)
	0017-00003-0309	LAMP 12V., 25W. (2 REQ'D.)
	0017-00101-0626	#8-32 x 3/4 SLT. PAN HD. M.S. (4 REQ'D.)
	0017-00103-0061	#8-32 HEX NUT W/SEMS (4 REQ'D.)
13	0586-00036-0000	ON-OFF SWITCH
	0567-00106-0100	SWITCH MTG. PLATE
	0017-00101-0025	#8 x 1/2 STL. HEX HD. WD. SCR. (4 REQ'D.)

**NO. 932 - PAC-MAN UP-RIGHT - INTERIOR ACCESS PICTURE**

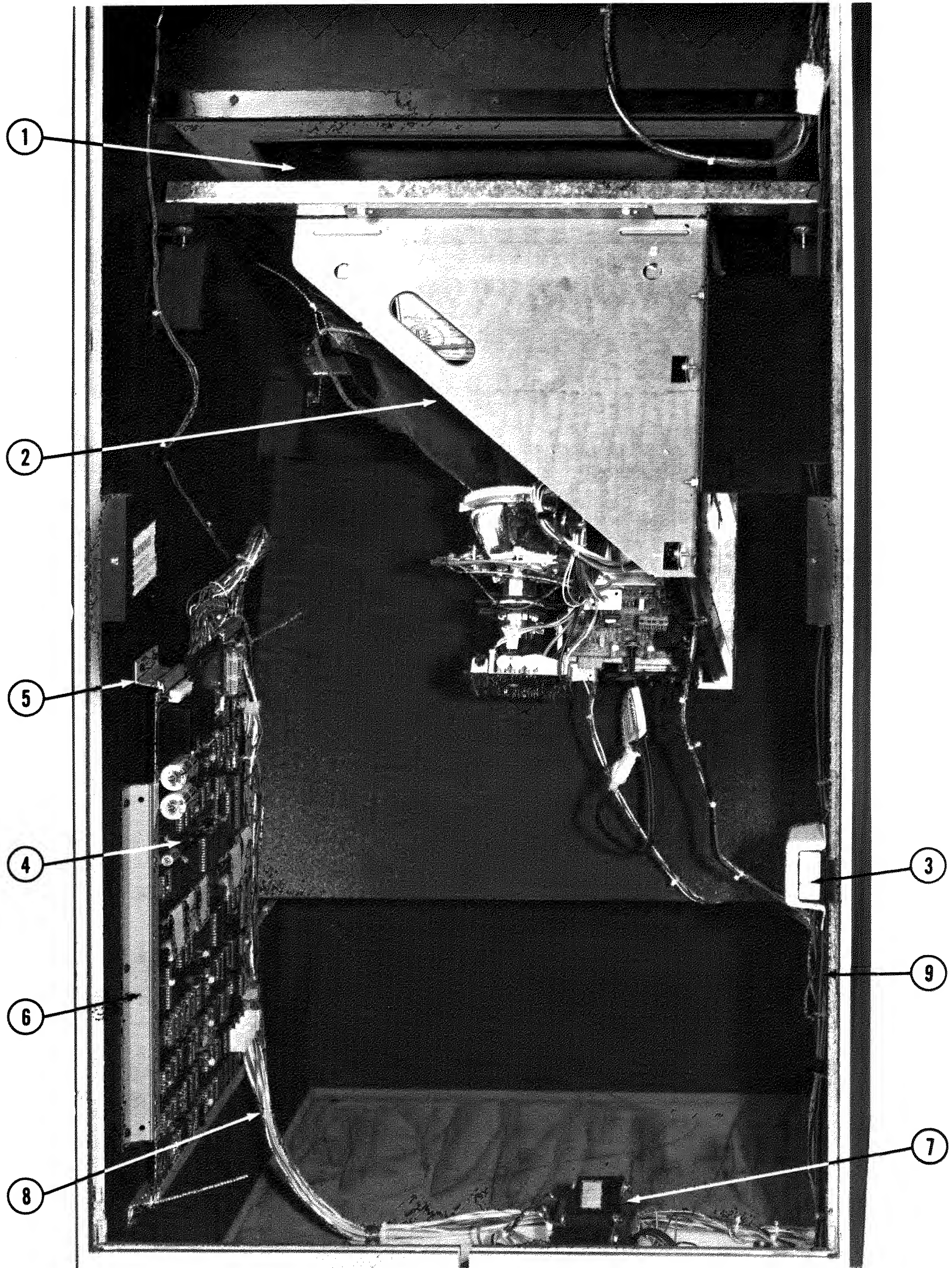

NO. 932 - PAC-MAN UP-RIGHT - INTERIOR ACCESS PICTURE

***ORDER BY PART NUMBER ONLY***

ITEM	PART NO	DESCRIPTION
1	A866-00064-0000	T.V. BEZEL & PLEXI ASSY.
2	A866-00202-0000	COLOR MONITOR & MTG. CHANNEL ASSY.
	0017-00101-0115	#8-32 x 2" HEX MACH. SCR. (5 REQ'D.)
	0017-00101-0639	#8-32 x 1-1/4 CARRIAGE BOLT
	0017-00101-0628	#8-32 x 3/4 CARRIAGE BOLT (4 REQ'D.)
	0017-00104-0022	#8 WASHER (10 REQ'D.)
	0017-00103-0061	#8-32 HEX NUT SEMS (10 REQ'D.)
3	A866-00035-00XF	INTERLOCK SW. BRKT. ASSY.
	0017-00032-0071	INTERLOCK SWITCH
4	A082-91375-B000	GAME LOGIC P.C. ASSY.
5	0624-00902-0300	P.C. SUPPORT BRKT. - 2-1/2 IN. (3 REQ'D.)
6	0624-00902-0100	P.C. SUPPORT BRKT. - 12 IN. (2 REQ'D.)
	0017-00101-0017	#6 x 1/2 BLK. SLT. HEX HD. SCR. (17 REQ'D.)
7	A932-00020-0000	TRANSFORMER BOARD ASSY.
8	A932-00005-0000	HIGH VOLTAGE CABLE ASSY.
	A932-00006-0000	LOW VOLTAGE CABLE ASSY.
	A932-00010-0000	CONTROL SHELF CABLE ASSY.
	A932-00019-0000	COIN DOOR CABLE ASSY.
9	A082-91109-C000	CREDIT MULTIPLIER BY-PASS P.C. BRD. ASSY.
		<u>ADDITIONAL PARTS LIST</u>
	0017-00009-0033	BASSICK CLAMP (2 REQ'D.)
	0603-00131-0000	STRIKE (2 REQ'D.)
	A866-00036-0000	TEST SWITCH & BRKT. ASSY. (MOUNTED ON BACK OF COIN DOOR)
	0017-00009-0477	CASH BOX-MOLDED
	A905-00026-0000	CASH BOX COVER ASSY.
	A624-00001-0000	CASH BOX GUIDE BRKT. ASSY.
	0624-00101-0000	CASH BOX GUIDE BRKT.
	0017-00101-0628	#8-32 x 3/4" CARRIAGE BOLT (4 REQ'D.)
	0017-00104-0022	#8 WASHER (4 REQ'D.)
	0017-00103-0061	#8-32 LOCK NUT SEMS (4 REQ'D.)
	A097-00001-0000	LOCK ASSY. - BACK DOOR
	0017-00009-0490	VENT GRILL - 5-5/8" SQ. (2 REQ'D.)
	0866-00905-0000	FISHPAPER SHIELD 4 IN. SQ.
	0866-00906-0000	FUSE SHIELD - TRANSFORMER BOARD

NO. 934 - PAC-MAN MINI - PHOTOGRAPH

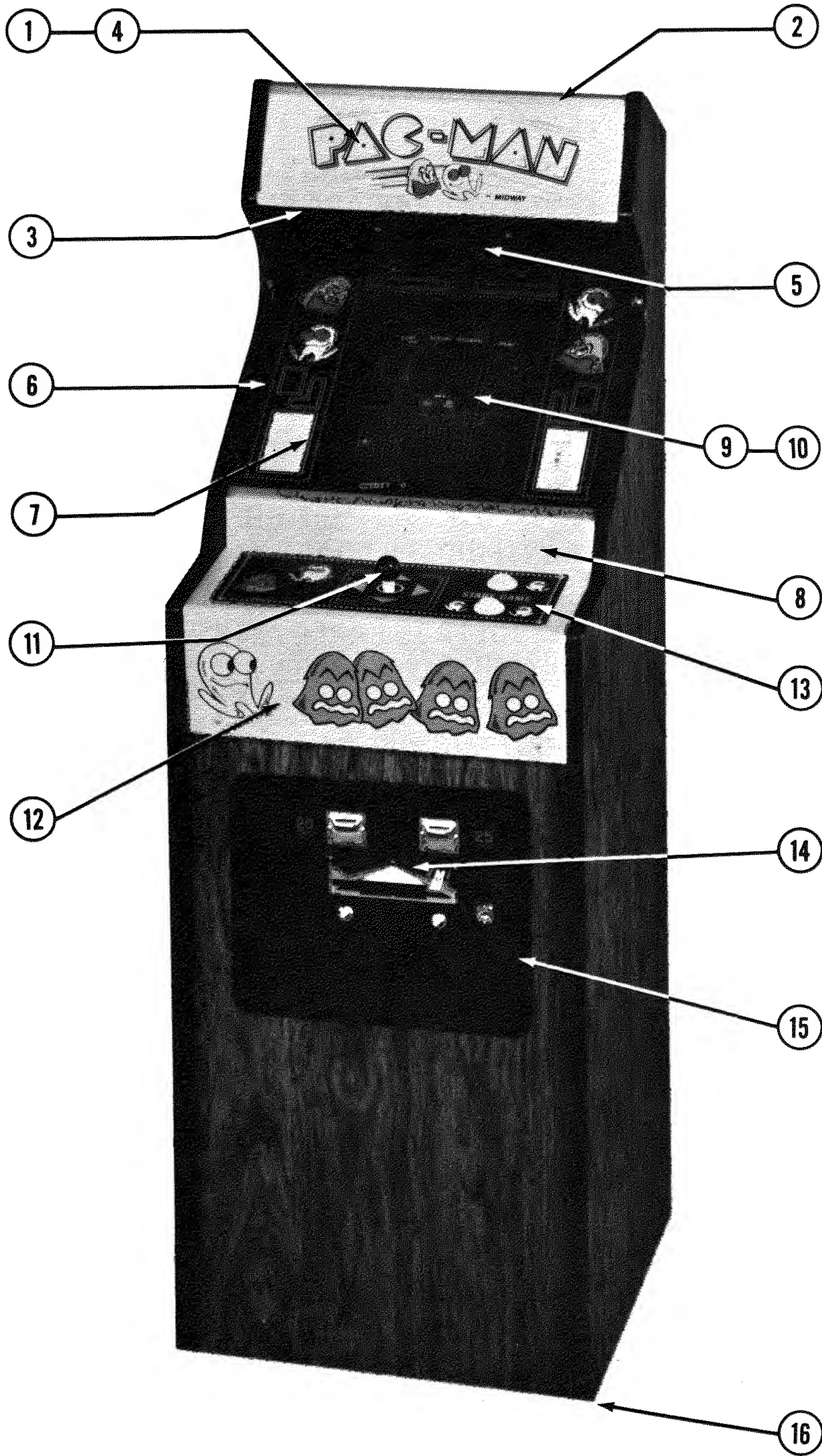



NO. 934 - PAC-MAN MINI - PHOTOGRAPH

**ORDER BY PART NUMBER ONLY**

ITEM	PART NO	DESCRIPTION
1	0934-00900-00XF	DISPLAY PLEXI (TOP) 17-3/16" x 5-3/4" x 3/16"
2	0905-00115-00XF	TOP BRACKET
3	0905-00116-00XF	BOTTOM BRACKET
	0017-00101-0117	#8 x 5/8 PHIL. TRS. HD. M.S. (6 REQ'D.)
	0017-00101-0789	#10-32 x 3/4 HEX BUTTON HD. SCR. (2 REQ'D.)
4	A934-00012-0000	INSERT ASSEMBLY
	0017-00003-0219	#194 WEDGE BASE LAMP 14V. 27A. (5 REQ'D.)
	0017-00031-0030	LIGHT SOCKET (5 REQ'D.)
5	A762-00028-0000	SPEAKER ASSY.
	0017-00009-0393	BLACK RECT. SPEACKER GRILL
	0017-00101-0642	#8-32 x 1-1/2 CARRIAGE BOLT (4 REQ'D.)
	0017-00103-0061	#8-32 HEX NUT W/SEMS (4 REQ'D.)
6	0905-00903-0100	GLASS EDGE CHANNEL - 14-1/2" LG. (2 REQ'D.)
7	0934-00902-00XF	MAIN DISPLAY GLASS - 17-13/16" x 13-1/8" x 3/16"
8	0934-00100-0000	GLASS CLAMPING PLATE
	0017-00101-0789	#10-32 x 3/4 HEX BUTTON HD. SCR. (2 REQ'D.)
9	A934-00007-0000	T.V. BEZEL ASSY. W/GREY PLEXI
10	0017-00003-0340	13" COLOR DUAL SYNC. HORIZ. MONITOR & CHASSIS - ELECTROHOME
11	A932-00008-0000	CONTROL ASSEMBLY
12	0934-00101-00XF	CONTROL PLATE
	0017-00101-0117	#8 x 5/8 PHIL. TRS. HD. SCR. (2 REQ'D.)
13	0934-00904-0000	CONTROL SHELF OVERLAY
	0017-00101-0118	#8-32 x 1-1/8 CARRIAGE BOLT (4 REQ'D.)
	0017-00104-0030	#8 WASHER (4 REQ'D.)
	0017-00103-0061	#8-32 HEX NUT W/SEMS (4 REQ'D.)
14	A090-00076-02BK	DOUBLE ENTRY COIN DOOR ASSY.
15	0090-00002-02BK	COIN DOOR FRAME
16	0017-00102-0048	3/8-16 x 2" LEG LEVELER (4 REQ'D.)
	0017-00103-0026	3/8-16 LEG LEVELER HEX NUT (4 REQ'D.)

**NO. 934 - PAC-MAN MINI - INTERIOR ACCESS PICTURE**

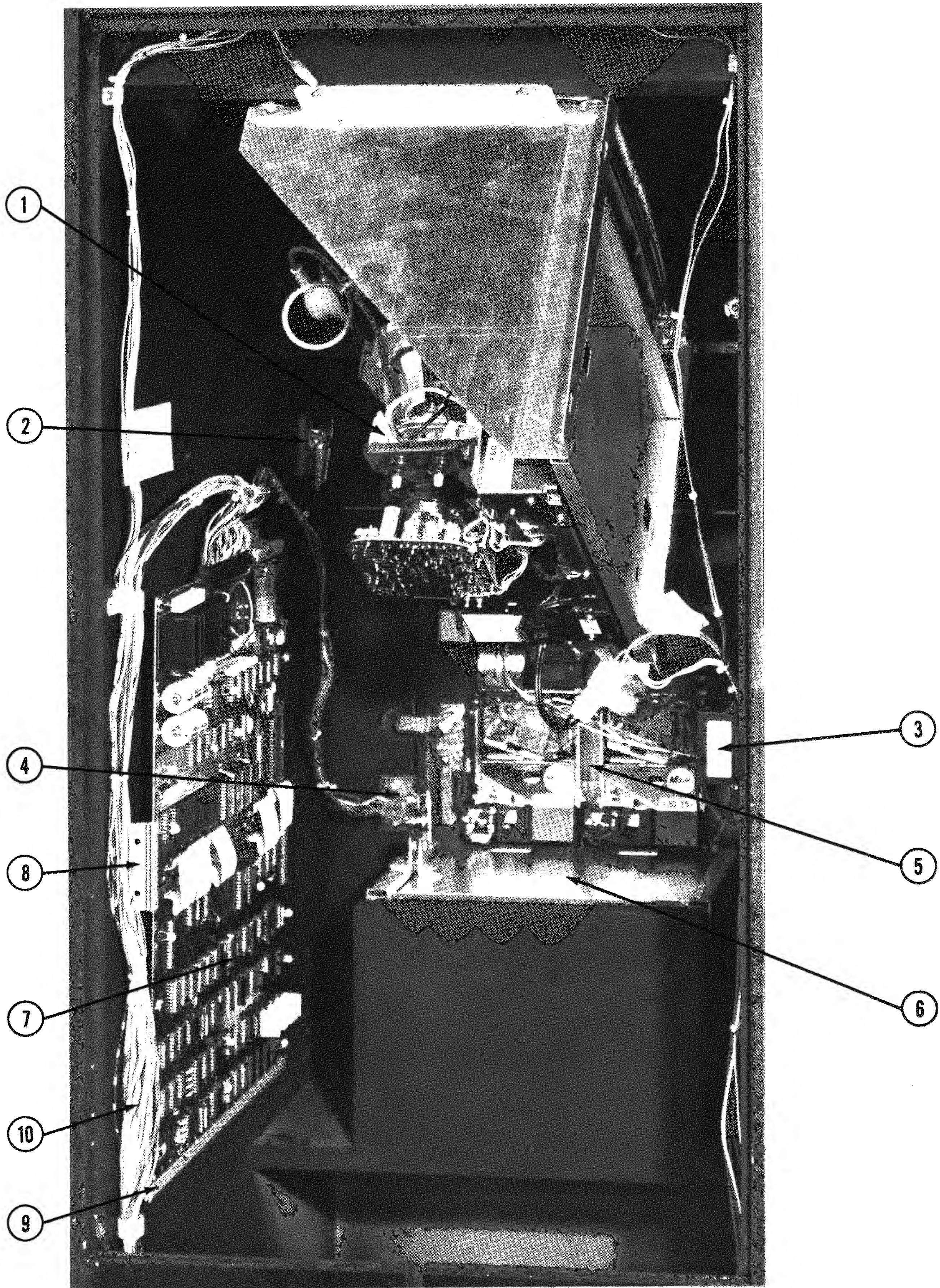

NO. 934 - PAC-MAN MINI - INTERIOR ACCESS PICTURE

ORDER BY PART NUMBER ONLY

ITEM	PART N <sup>o</sup>	DESCRIPTION
1	0017-00003-0340	13" COLOR DUAL SYNC. HORIZ. MONITOR & CHASSIS - ELECTROHOME
	0017-00004-0022	304 DYMAX GROUND STRAP
	0017-00102-0013	1/4-20 x 1-1/4 CARRIAGE BOLT (2 REQ'D.)
	0017-00102-0028	1/4-20 x 2-1/2 CARRIAGE BOLT (2 REQ'D.)
	0017-00104-0014	PERIPHERY WASHER (4 REQ'D.)
	0017-00103-0018	1/4 - 20 HEX NUT (2 REQ'D.)
2	0017-00009-0033	BASSICK CLAMP (2 REQ'D.)
	0603-00131-00XF	STRIKE (2 REQ'D.)
	0017-00101-0028	#8 x 3/4 SLT. HEX HD. SCREW (8 REQ'D.)
3	A151-00026-0000	INTERLOCK SW. & BRKT. ASSY.
	0017-00101-0028	#8 x 3/4 SLT. HEX HD. SCR. (2 REQ'D.)
4	A866-00036-0000	TEST SWITCH BRKT. ASSY.
5	A090-00076-02BK	DOUBLE ENTRY COIN DOOR ASSY.
6	A905-00028-0000	CASH BOX ASSY. W/HANDLE
	A905-00026-0000	CASH BOX COVER ASSY.
	A624-00001-0000	CASH BOX GUIDE BRKT. ASSY.
	0624-00101-0000	CASH BOX GUIDE BRKT.
7	A082-91375-B000	GAME LOGIC BOARD ASSY.
8	0624-00902-0300	P.C. SUPPORT BRKT. - 2-1/2 IN. (3 REQ'D.)
9	0624-00902-0100	P.C. SUPPORT BRKT. - 12 IN. (2 REQ'D.)
10	A934-00009-0000	HIGH VOLTAGE CABLE ASSY.
	A934-00008-0000	LOW VOLTAGE CABLE ASSY.
	A934-00010-0000	CONTROL SHELF CABLE ASSY.
	A934-00013-0000	DISPLAY INSERT CABLE ASSY.
	A932-00019-0000	COIN DOOR CABLE ASSY.
		<u>NOT SHOWN LIST</u>
	A082-91109-C000	CREDIT MULT. BYPASS P.C. BRD. ASSY.
	A934-00011-0000	TRANSFORMER BOARD ASSY.
	0017-00032-0083	ON-OFF SWITCH
	0567-00106-0100	SWITCH MTG. PLATE
	0017-00101-0028	#8 x 3/4 SLT. HEX HD. SCR. (4 REQ'D.)
	0017-00009-0490	VENT GRILL - BOTTOM BACK DOOR (2 REQ'D.)
	0618-00117-0000	VENT GRILL - TOP BACK DOOR
	0017-00101-0015	#6 x 1/2 SLT. HEX HD. SCR. (4 REQ'D.)
	0934-00903-0000	PROTECTIVE BUBBLE - BACK DOOR
	0017-00101-0628	#8-32 x 3/4 CARRIAGE BOLT (10 REQ'D.)
	0017-00103-0061	#8-32 HEX NUT W/SEMS (10 REQ'D.)
	A151-00029-0000	LOCK ASSY. - BACK DOOR

# PAC-MAN - CONTROL ASSEMBLY

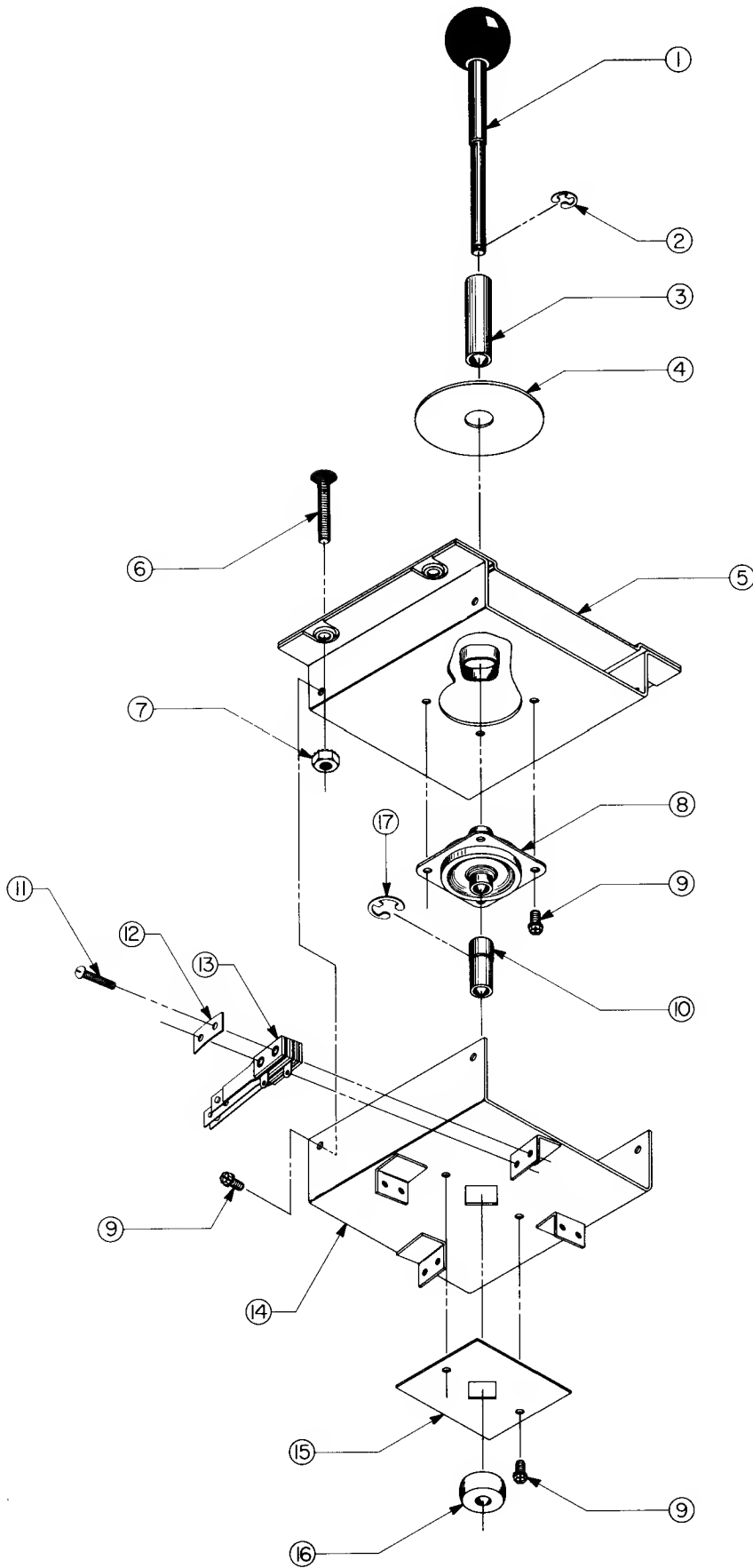

PAC-MAN - CONTROL ASSEMBLY

*ORDER BY PART NUMBER ONLY*

ITEM	PART NO	DESCRIPTION
1	A921-00012-0000	SHAFT & BALL ASSY. - FIRST 3,000 GAMES
1	A932-00022-0000	SHAFT & BALL ASSY.
2	0017-00100-0025	1/4" E-RING
3	0921-00702-0000	STOP SPACER
4	0921-00902-0000	SLIDE PLATE
5	A932-00011-00XF	SPOT WELD ASSY.
6	0017-00101-0713	#8-32 x 1" SLT. FLAT HD. SCREW (4 REQ'D.)
7	0017-00103-0061	#8-32 HEX NUT W/SEMS (4 REQ'D.)
8	0932-00902-0000	GROMMET
9	0017-00101-0598	#8-32 x 5/16 SLT. HEX HD. M.S. (10 REQ'D.)
10	0921-00701-0000	SLEEVE
11	0017-00101-0528	#5-40 x 3/4 SLT. RND. HD. SCR. (8 REQ'D.)
12	0020-00202-0000	SWITCH PLATE (4 REQ'D.)
13	A932-00009-0000	SWITCH ASSEMBLY (4 REQ'D.)
14	A932-00012-00XF	STOP PLATE & SWITCH BRKT. ASSY.
15	0932-00904-0000	WEAR PLATE
16	0921-00700-0000	ACTUATOR
17	0017-00100-0115	7/16" E-RING

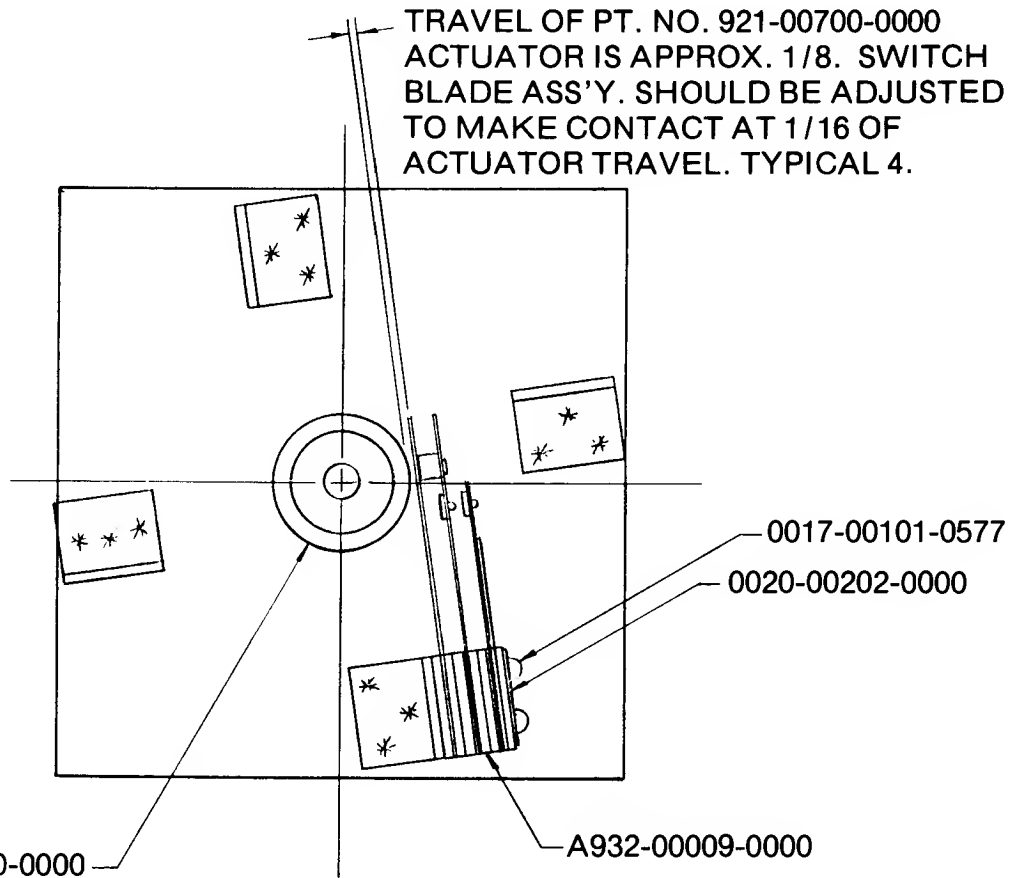

**NO. 932 & 934 PAC-MAN UP-RIGHT & MINI - PUSH BUTTON ASSY.**

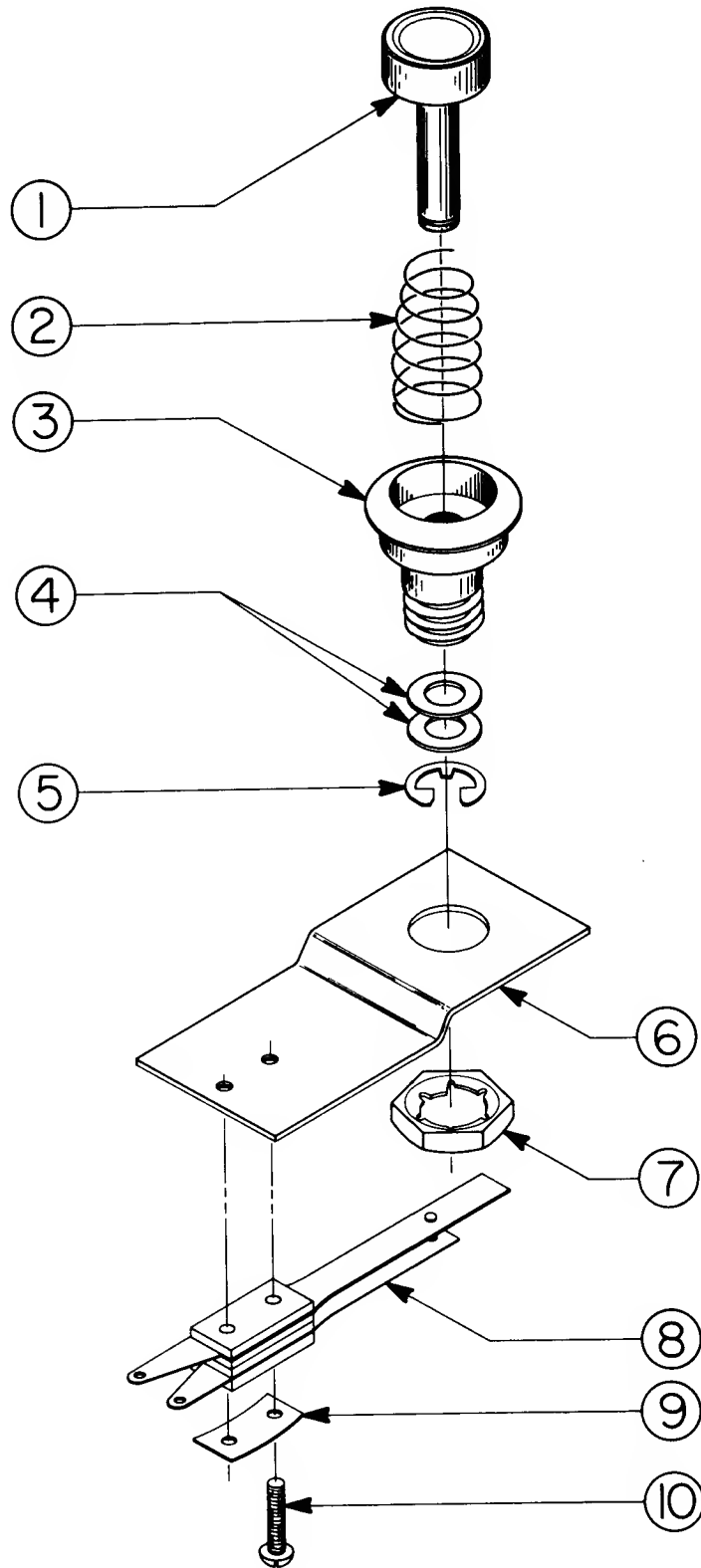

NO. 932 & 934 PAC-MAN UP-RIGHT & MINI - PUSH BUTTON ASSY.

*ORDER BY PART NUMBER ONLY*

ITEM	PART N <sup>o</sup>	DESCRIPTION
1	0017-00009-B384	RED BUTTON - MINI ONLY
1	0017-00009-0384	BUTTON
2	0010-00593-0000	SPRING
3	0017-00009-0376	BUTTON HOUSING
4	0017-00104-0028	FLAT WASHER (2 REQ'D.)
5	0017-00100-0025	E-RING
	A761-00014-0000	PUSH BUTTON ASSY. (FIRST 5 ITEMS) - MINI ONLY
	A739-00012-0000	PUSH BUTTON ASSY. (FIRST 5 ITEMS)
6	0586-00107-0000	MOUNTING BRKT.
7	0017-00103-0054	PAL NUT
8	A739-00016-0000	SWITCH ASSY.
9	0020-00202-0000	SWITCH PLATE
10	0017-00101-0526	#5-40 x 9/16 PHIL. HD. M.S. (2 REQ'D.)

**NO. 932 & 934 PAC-MAN UP-RIGHT & MINI - FRONT DOOR ASSY.**

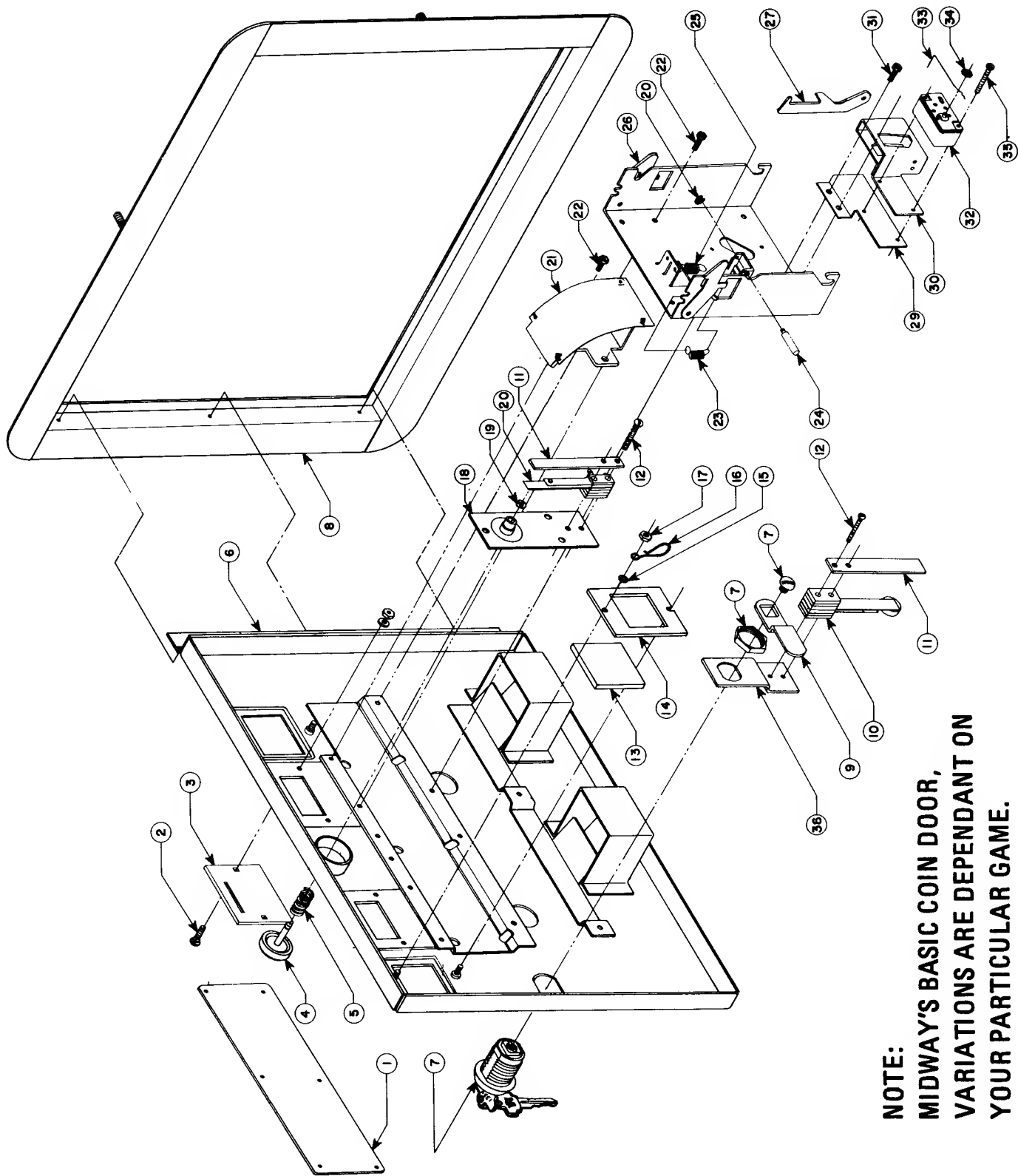

**NOTE:  
MIDWAY'S BASIC COIN DOOR,  
VARIATIONS ARE DEPENDANT ON  
YOUR PARTICULAR GAME.**



NO. 932 & 934 PAC-MAN UP-RIGHT & MINI - FRONT DOOR ASSY.

*ORDER BY PART NUMBER ONLY*

ITEM	PART NO	DESCRIPTION
1	0090-00902-0000	DRESS PLATE
	0090-00902-0100	DRESS PLATE W/O BUTTON TO START GAME
2	0017-00101-0552	#6-32 x 1/4 CARRIAGE BOLT (2)
3	0090-00117-03XF	COIN ENTRY PLATE (25¢)
4	0090-00906-0000	PLASTIC START BUTTON
5	0010-00007-0000	COMPRESSION SPRING
6	A090-00020-2003	DOOR ASSY. DOUBLE ENTRY
7	0017-00005-0050	DOOR LOCK & KEY WITH SCREW & NUT
8	0090-00002-02BK	DOUBLE DOOR FRAME
9	0017-00005-0041	421 N.S. CAM
10	0090-00901-0000	DOOR SWITCH
	0090-00126-01XF	SWITCH BACKUP PLATE
12	0017-00101-0528	#5-40 x 3/4" LNG. M.S.
13	0090-00903-9500	25¢ WINDOW
14	0090-00143-0000	COIN PLEX RETAINER
15	0017-00104-0002	SPLIT LOCK WASHER
16	0017-00007-0019	KEY HOOK
17	0017-00103-0005	#6-32 HEX NUT
18	0090-00010-0000	SW. PLATE & OILLITE ASSY.
19	0017-00100-0018	"E" RING
20	0090-00131-0000	SWITCH
21	0090-00104-0000	TOP & BTM. COIN CHUTE W/BRKT. ASSY.
22	0017-00101-0598	#8 x 5/16 SCREW
23	0010-00181-0100	SPRING
24	0090-00129-00XF	PIVOT POST
25	0010-00134-0000	SPRING
26	0090-00008-0000	ACCEPTOR FRAME ASSY.
27	0093-00155-00XF	REJECTOR LEVER
28	0017-00100-0012	"E" RING
29	0090-00162-00XF	COIN SWITCH MTG. BRKT. - SMALL (AMERICAN)
29	0090-00163-00XF	COIN SWITCH MTG. BRKT. - LARGE
30	0017-00005-0203	COIN SWITCH CHUTE - SMALL (AMERICAN)
30	0017-00005-0204	COIN SWITCH CHUTE - LARGE
31	0017-00101-0555	#6-32 x 5/16 SCREW
32	0017-00005-0195	COIN SWITCH
33	0010-00599-0000	COIN SWITCH WIRE
34	0017-00007-0132	PUSH-ON RING (BLK.)
35	0017-00101-0698	#4-40 x 3/4 SCREW (2 REQ'D.)
36	0090-00128-00XF	SWITCH BRKT. - DOOR TILT
	A090-00061-0000	ANTI-STRING DEVICE ASSY. (REPLACES ITEM 30)
	A090-00064-0000	ANTI-PENNY DEVICE ASSY.

**NO. 933 - PAC-MAN COCKTAIL - PHOTOGRAPH**

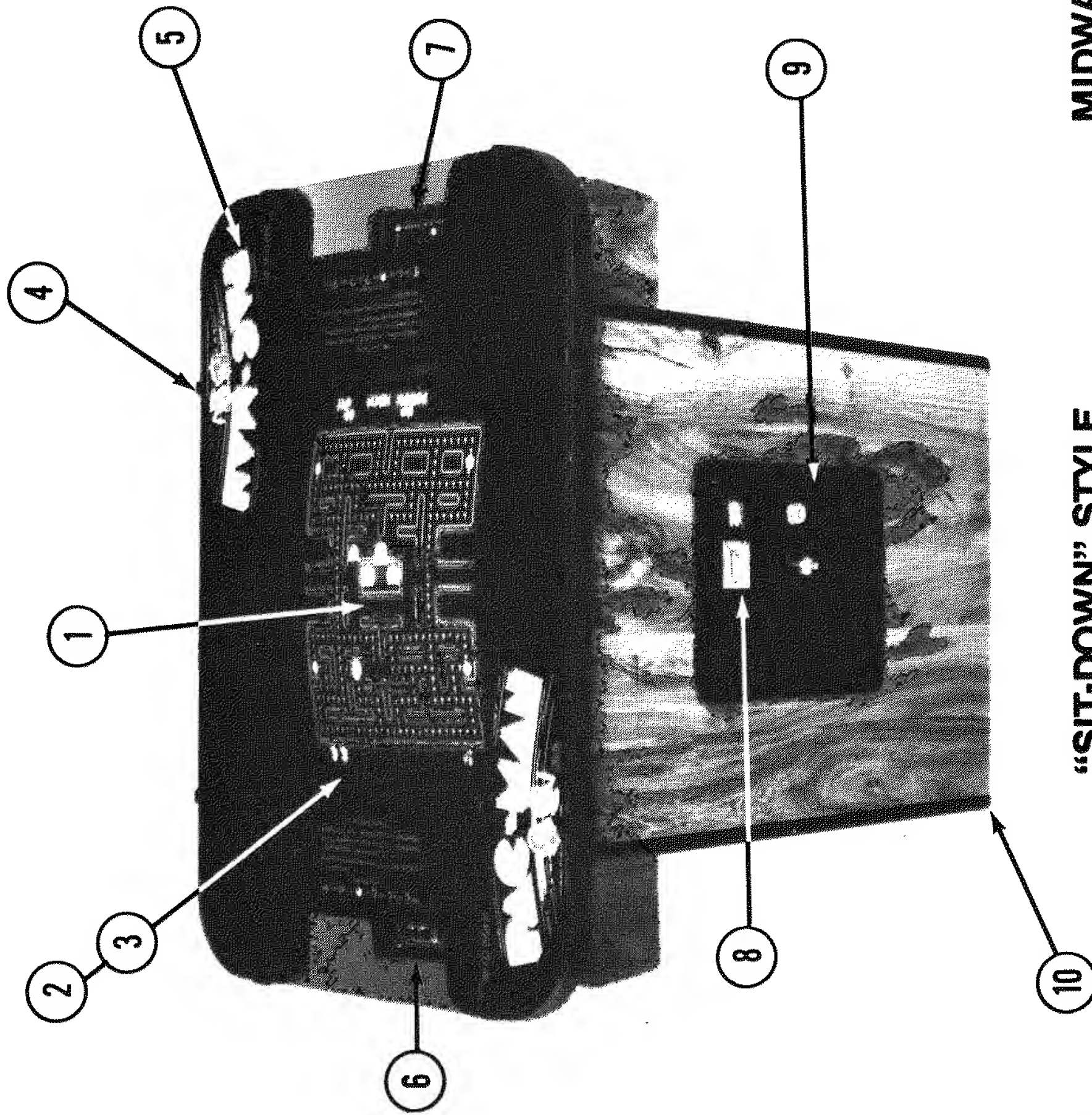

**“SIT-DOWN” STYLE**  
**DIMENSIONS:**  
 Height: 29” (74 cm)  
 Width: 32” (81.25 cm)  
 Depth: 22” (56 cm)

**MIDWAY**  
**COCKTAIL TABLE**  
**MODELS**  
 with Flip-Flop Screen  
 for 2 players

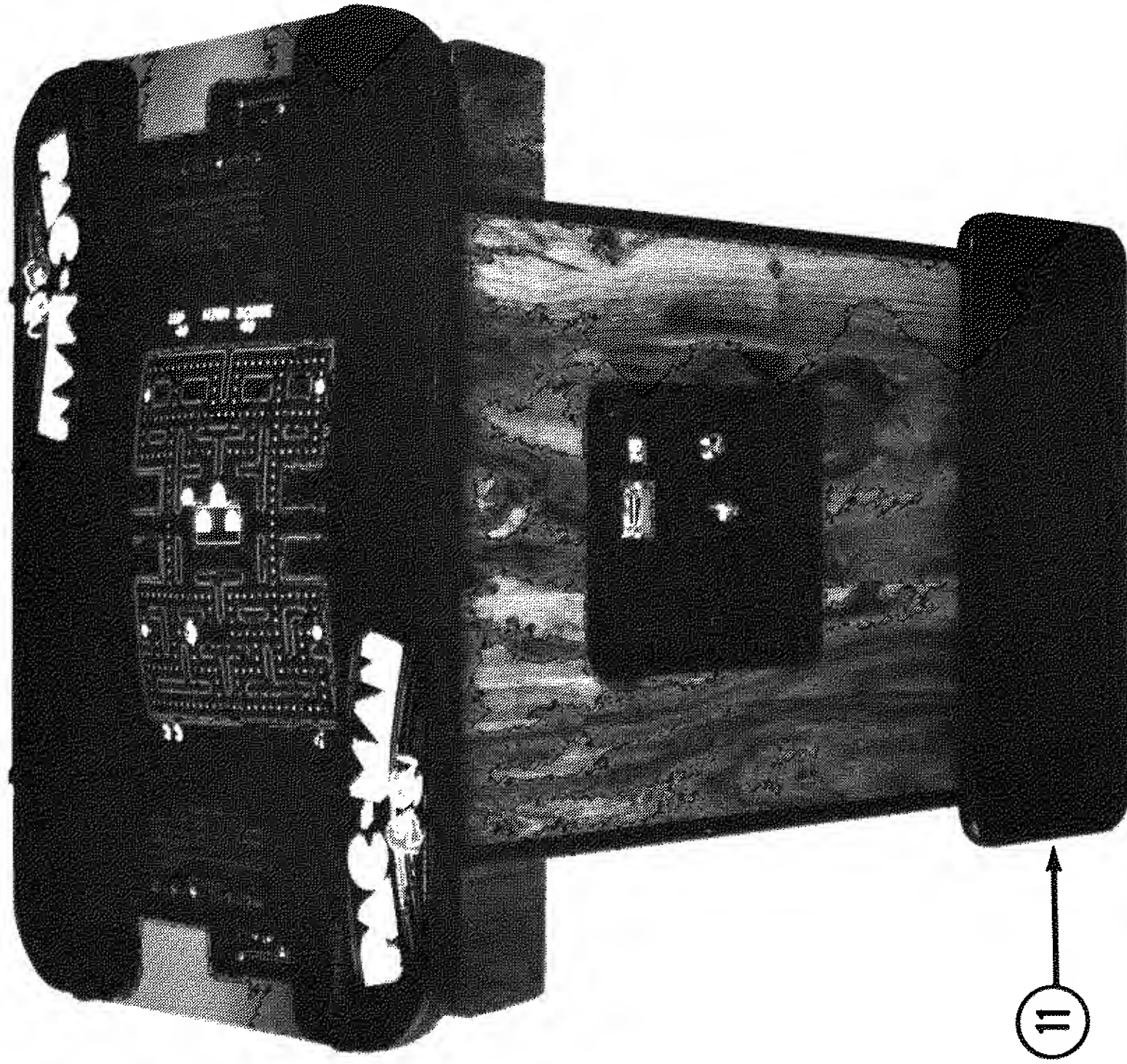

**With Base Accessory**  
 Raises cocktail model  
 to height of 38”  
 (96.5 cm) for upright  
 play.

© Copyright 1980 MIDWAY MFG. CO. All rights reserved.

NO. 933 - PAC-MAN COCKTAIL - PHOTOGRAPH

*ORDER BY PART NUMBER ONLY*

ITEM	PART N <sup>o</sup>	DESCRIPTION
1	0017-00003-0339	19" COLOR DUAL SYNC. HORIZ. MONITOR - ELECTROHOME
	A869-00007-00XF	MONITOR SUPPORT ASSY. - L.H.
	A869-00007-01XF	MONITOR SUPPORT ASSY. - R.H.
	0869-00114-00XF	SUPPORT ANGLE (2 REQ'D.)
	0017-00101-0023	#8 x 3/8 PHIL. TRS. HD. SCR. (10 REQ'D.)
2	0869-00902-0000	T.V. BEZEL
3	0869-00907-0000	PLEXI 15" x 18-3/4"
4	0775-00104-00XF	GLASS CLIP (8 REQ'D.)
	0017-00101-0017	#8 x 5/8 PHIL. TRS. HD. S.M.S. (16 REQ'D.)
5	0933-00900-00XF	GLASS TOP - 32" x 22" x 1/4"
6	0933-00901-0000	DECORATIVE CONTROL PANEL OVERLAY - PLAYER #1
	0933-00100-00XF	STEEL CONTROL PANEL - PLAYER #1
7	0933-00901-0100	DECORATIVE CONTROL PANEL OVERLAY - PLAYER #2
	0933-00100-01XF	STEEL CONTROL PANEL - PLAYER #2
	0017-00101-0341	#6 x 1/4 PHIL. TRS. HD. SCR (4 REQ'D. EACH)
	0017-00101-0620	#8-32 x 1/2 CARRIAGE BOLT (4 REQ'D. EACH)
	0017-00103-0061	#8-32 HEX NUT W/SEMS (4 REQ'D. EACH)
	0017-00032-0051	BUTTON SWITCH (2 REQ'D.) PLAYER #1 ONLY
	0921-00903-0000	LIGHT SHIELD (1 REQ'D. EACH)
	0017-00031-0044	LAMP SOCKET - WEDGE BASE (2 REQ'D. EACH)
	0017-00003-0219	#194 LAMP 14V. 27A. (2 REQ'D. EACH)
	0017-00101-0555	#6-32 x 5/16 SLT. HEX HD. SCR. (2 REQ'D. EACH)
8	A090-00078-00BK	SINGLE COIN DOOR ASSY.
9	0090-00002-01BK	COIN DOOR FRAME
10	0017-00102-0048	3/8-16 x 2" LEG LEVELERS (4 REQ'D.)
	0017-00103-0026	3/8-16 LEG LEVELER HEX NUTS (4 REQ'D.)
11	0933-00501-0000	WOOD PEDESTAL - OPTIONAL
		<u>NOT SHOWN LIST</u>
	0869-00901-00XF	HINGE (CABINET TOP)
	0017-00101-0672	#10-32 x 1-1/8 CARRIAGE BOLT (8 REQ'D.)
	0017-00104-0004	#10 WASHER (8 REQ'D.)
	0017-00103-0010	#10-32 HEX NUT (8 REQ'D.)
	0017-00003-0187	6" x 9" SPEAKER 8 OHM, 9W
	0017-00009-0393	BLACK SPEAKER GRILL
	0017-00101-0642	#8-32 x 1-1/2 CARRIAGE BOLT (4 REQ'D.)
	0017-00103-0061	#8-32 HEX NUT W/SEMS (4 REQ'D.)

NO. 933 - PAC-MAN COCKTAIL - PHOTOGRAPH

*ORDER BY PART NUMBER ONLY*

ITEM	PART N <sup>o</sup>	DESCRIPTION
	0017-00003-0222	<u>FAN ASSY.</u>
	0775-00110-00XF	FAN
	0749-00106-00XF	FAN PLATE
	0017-00101-0347	VENT SCREEN
	0017-00104-0009	#6-32 x 1/2 PHIL R.H.M.S. (4 REQ'D.)
	0017-00103-0005	#6 EXT. WASHER (4 REQ'D.)
	0017-00101-0026	#6-32 HEX NUT (4 REQ'D.)
		#8 x 5/8 SLOT HEX HD. M.S. (4 REQ'D.)

NO. 933 - PAC-MAN COCKTAIL - ADDITIONAL PARTS LIST

*ORDER BY PART NUMBER ONLY*

ITEM	PART NO	DESCRIPTION
	A749-00003-0000	COIN BOX ASSY.
	A627-00056-0000	COIN BOX COVER ASSY.
	A625-00024-0000	COIN BOX GUIDE BRKT. ASSY.
	0625-00117-0000	COIN BOX SIDE CHANNELS
	0017-00101-0628	#8-32 x 3/4 CARRIAGE BOLT (4 REQ'D.)
	0017-00103-0008	#8-32 HEX NUT
	A749-00005-0000	INTERLOCK SWITCH ASSY.
	0017-00101-0028	#8 x 3/4 HEX HD. S.M.S. (6 REQ'D.)
	0017-00032-0083	ON-OFF SWITCH
	0567-00106-0100	SWITCH MTG. PLATE
	0017-00009-0033	BASSICK CLAMP (2 REQ'D.)
	0017-00101-0026	#8 x 5/8 HEX HD. M.S. (4 REQ'D.)
	0610-00132-0000	STRIKE (2 REQ'D.)
	0017-00101-0028	#8 x 3/4 HEX HD. S.M.S. (4 REQ'D.)
	A866-00036-0000	TEST SWITCH BRKT. ASSY.
	0869-00908-0000	FISHPAPER SHIELD
	A082-91348-C000	CREDIT MULTIPLIER P.C. ASSY.
	A082-91375-B000	GAME LOGIC BRD. ASSY.
	0624-00902-0100	P.C. SUPPORT BRKT. - 12'' (2 REQ'D.)
	0624-00902-0300	P.C. SUPPORT BRKT. - 2-1/2'' (2 REQ'D.)
	0624-00902-0500	P.C. SUPPORT BRKT. - 6''
	0017-00101-0028	#8 x 3/4 HEX HD. M.S. (12 REQ'D.)
	0017-00104-0031	#8 WASHER (12 REQ'D.)
	A933-00008-0000	HIGH VOLTAGE CABLE ASSY.
	A933-00009-0000	LOW VOLTAGE CABLE ASSY.
	A933-00012-0000	COIN DOOR CABLE ASSY.
	A933-00011-0000	CONTROL SHELF CABLE ASSY. - PLAYER #2
	A933-00010-0000	CONTROL SHELF CABLE ASSY. - PLAYER #1
	A933-00013-0000	TRANSFORMER BOARD ASSY.
	0017-00009-0393	BLACK VENT GRILL (2 REQ'D.)
	0017-00101-0118	#8-32 x 1-1/8 CARRIAGE BOLT (8 REQ'D.)
	0017-00103-0061	#8-32 HEX NUT W/SEMS (8 REQ'D.)

**NO. 933 - PAC-MAN COCKTAIL - FRONT DOOR ASSY.**

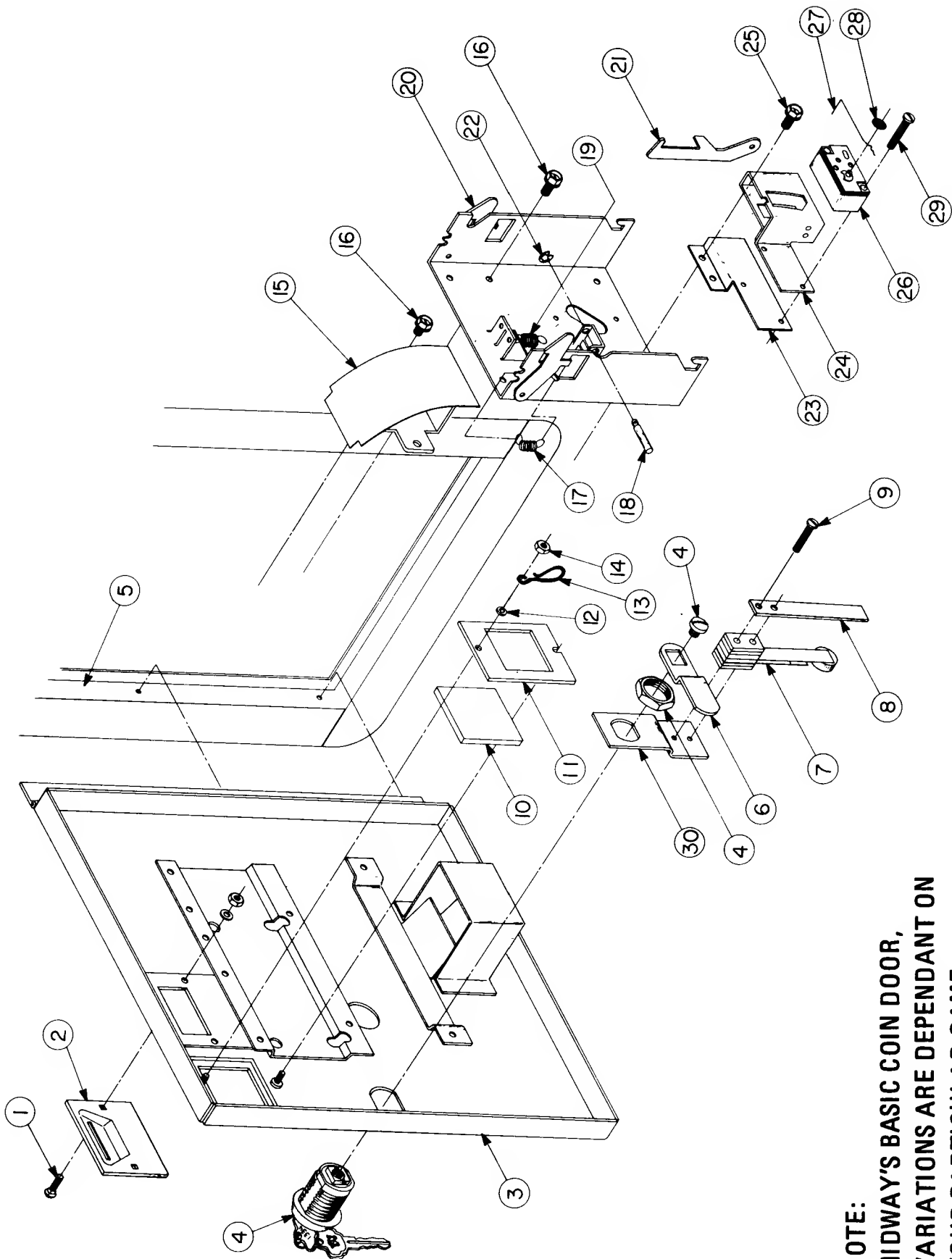

**NOTE:  
MIDWAY'S BASIC COIN DOOR,  
VARIATIONS ARE DEPENDANT ON  
YOUR PARTICULAR GAME.**

NO. 933 - PAC-MAN COCKTAIL - FRONT DOOR ASSY.

*ORDER BY PART NUMBER ONLY*

ITEM	PART NO	DESCRIPTION
1	0017-00101-0552	#6-32 x 1/4 CARRIAGE BOLT (2 REQ'D.)
2	0090-00117-03XF	COIN ENTRY PLATE (25¢)
3	A090-00058-0000	DOOR ASSY. SINGLE ENTRY
4	0017-00005-0050	DOOR LOCK & KEY WITH SCREW & NUT
5	0090-00002-01BK	SINGLE DOOR FRAME
6	0017-00005-0041	421 N.S. CAM
7	0090-00901-0000	DOOR SWITCH
8	0090-00126-01XF	SWITCH BACKUP PLATE
9	0017-00101-0528	#5-40 x 3/4 LONG M.S. (2 REQ'D.)
10	0090-00903-9500	25¢ WINDOW
11	0090-00143-0000	COIN PLEX RETAINER
12	0017-00104-0002	SPLIT LOCK WASHER (2 REQ'D.)
13	0017-00007-0019	KEY HOOK
14	0017-00103-0005	#6-32 HEX NUT (2 REQ'D.)
15	0090-00104-0000	TOP & BOTTOM COIN CHUTE W/BRKT. ASSY.
16	0017-00101-0598	#8-32 x 5/16 SCREW (4 REQ'D.)
17	0010-00181-0100	SPRING
18	0090-00129-00XF	PIVOT POST
19	0010-00134-0000	SPRING
20	0090-00008-0000	ACCEPTOR FRAME ASSY.
21	0093-00155-00XF	REJECTOR LEVER
22	0017-00100-0012	E-RING
23	0090-00162-00XF	COIN SWITCH MTG. BRKT. - SMALL (AMERICAN)
23	0090-00163-00XF	COIN SWITCH MTG. BRKT. - LARGE
24	0017-00005-0203	COIN SWITCH CHUTE - SMALL (AMERICAN)
24	0017-00005-0204	COIN SWITCH CHUTE - LARGE
25	0017-00101-0555	#6-32 x 5/16 SCREW (2 REQ'D.)
26	0017-00005-0195	COIN SWITCH
27	0010-00599-0000	COIN SWITCH WIRE
28	0017-00007-0132	PUSH-ON RING (BLK.)
29	0017-00101-0698	#4-40 x 3/4 SCREW (2 REQ'D.)
30	0090-00128-00XF	SWITCH BRKT. - DOOR TILT
	A090-00061-0000	ANTI-STRING DEVICE ASSY. (REPLACES ITEM 24)
	A090-00064-0000	ANTI-PENNY DEVICE ASSY.

**NO. 932 & 934 - PAC-MAN UP-RIGHT & MINI TRANSFORMER BOARD ASSEMBLY**

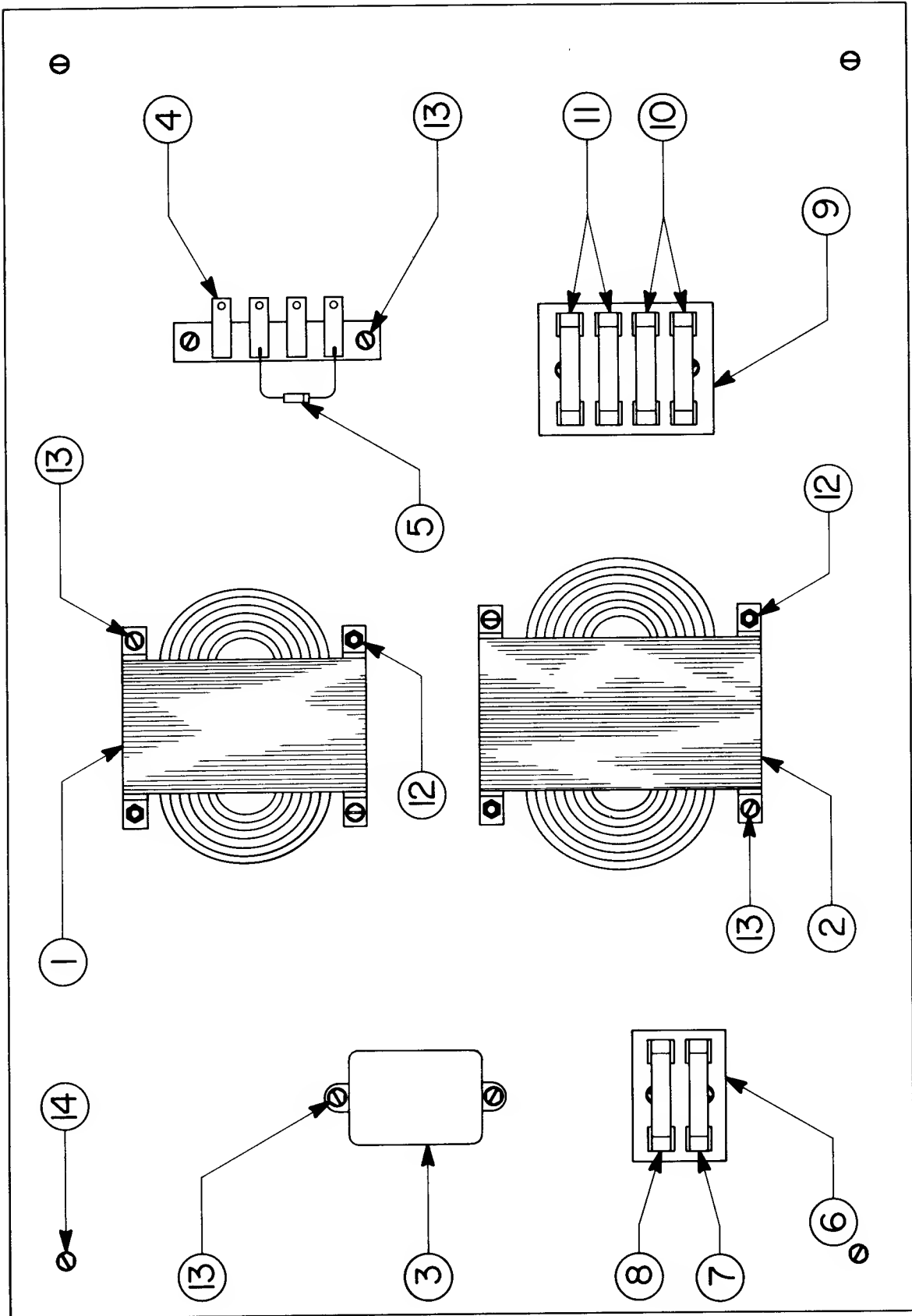



*ORDER BY PART NUMBER ONLY*

ITEM	PART N <sup>o</sup>	DESCRIPTION
1	MT00-00080-0000	TRANSFORMER - 110 VOLT
2	MT00-00081-0000	TRANSFORMER - 240 VOLT
3	0017-00003-0114	NOISE FILTER
4	A932-00024-0000	TERMINAL STRIP ASSY.
5	0064-030XX-XXPX	IN4004 400 V. DIODE
6	0720-00001-0200	2 POSITION FUSE CLIP
7	0017-00003-0004	FUSE 2A. SLO-BLO
8	0017-00003-0261	FUSE 1.5A. SLO-BLO
9	0720-00001-0400	4 POSITION FUSE CLIP
10	0017-00003-0169	FUSE 5A. (2 REQ'D.)
11	0017-00003-0001	FUSE 1A. (2 REQ'D.)
12	0017-00101-0637	#8-32 x 1-1/4 CARRIAGE BOLT (4 REQ'D.)
	0017-00103-0008	#8-32 HEX NUT (4 REQ'D.)
13	0017-00101-0014	#6 x 1/2 SLT. HEX HD. WD. SCR. (12 REQ'D.)
14	0017-00101-0018	#6 x 3/4 SLT. HEX HD. WD. SCR. (4 REQ'D.)
	A866-00049-0000	LINE CORD ASSY. - NOT SHOWN

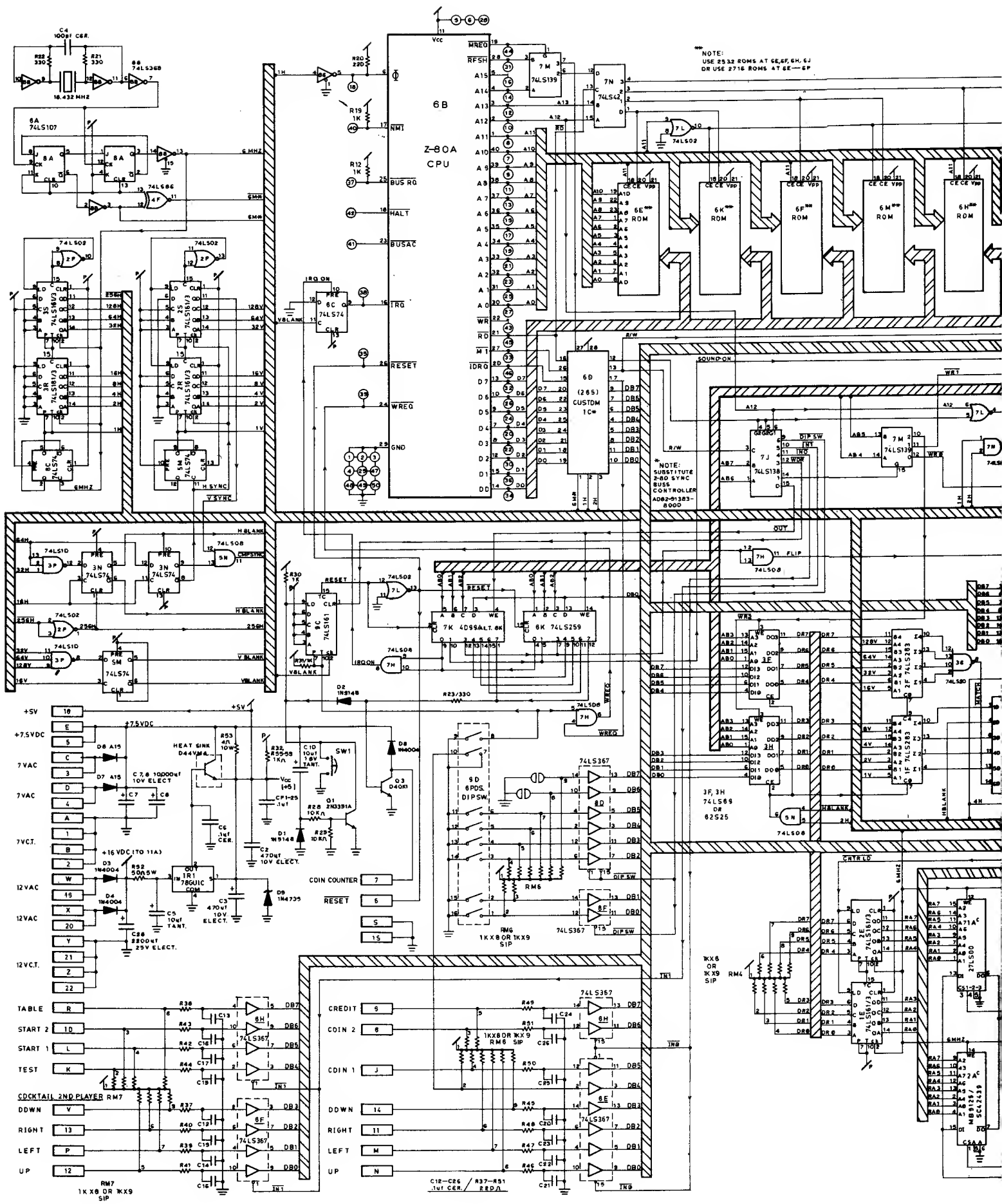

NOTE:  
USE 2532 ROMS AT 5E,5F,5H, 6J  
OR USE 2716 ROMS AT 5E-6F

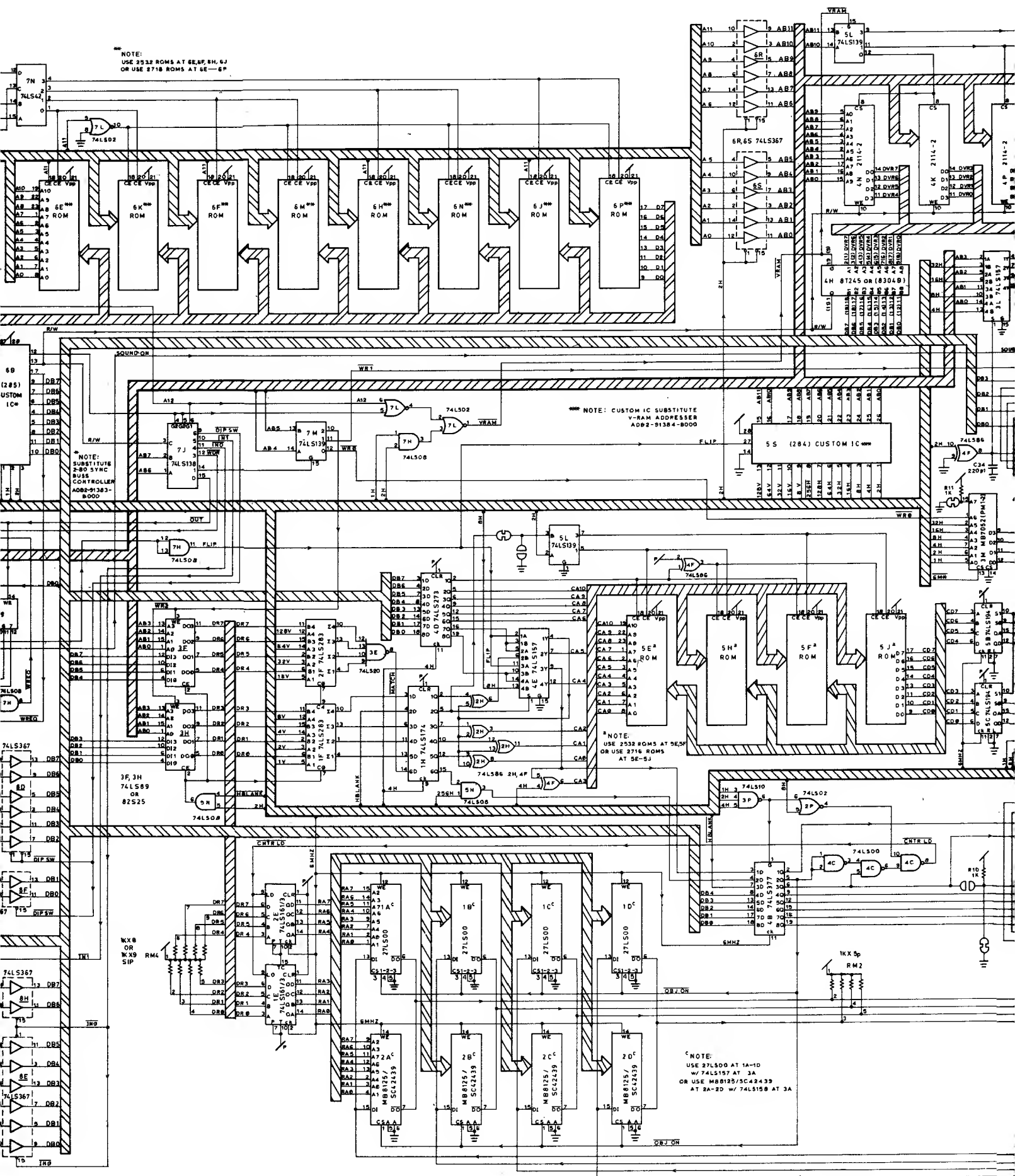

NOTE: CUSTOM IC SUBSTITUTE  
V-RAM ADDRESSER  
ADR2-91384-8000

NOTE: SUBSTITUTE  
2-80 SYNC  
BUSSES  
CONTROLLER  
ADDR-91383-  
8000

NOTE:  
USE 2532 ROMS AT 5E,5F  
OR USE 2716 ROMS  
AT 5E-5J

NOTE:  
USE 27LS00 AT 1A-1D  
W/ 74LS157 AT 3A  
OR USE MB8125/SC42439  
AT 2A-2D W/ 74LS158 AT 3A

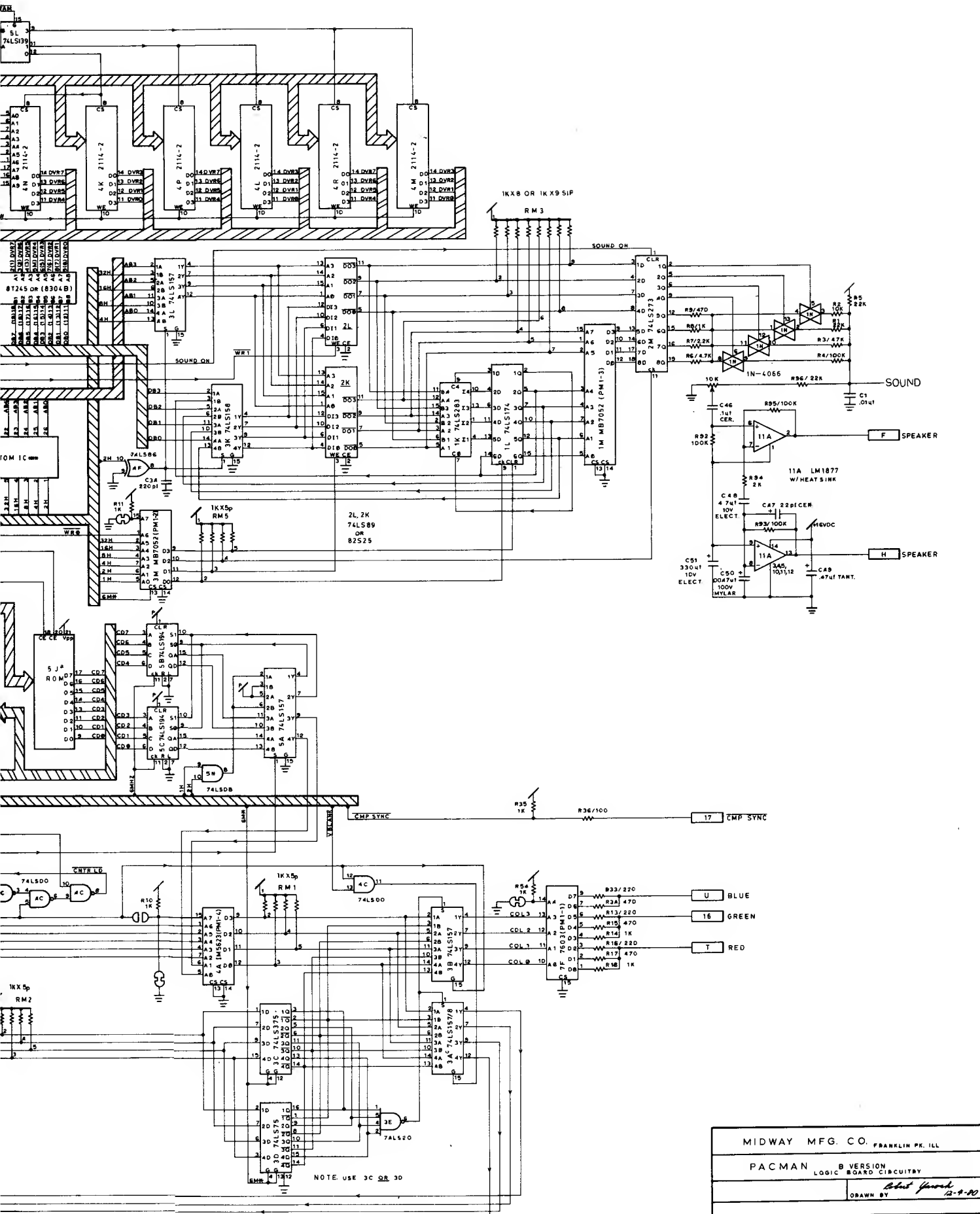

NOTE USE 3C OR 3D

MIDWAY MFG. CO. FRANKLIN PK. ILL	
PACMAN B VERSION LOGIC BOARD CIRCUITRY	
DRAWN BY <i>Robert Hancock</i> 12-9-80	

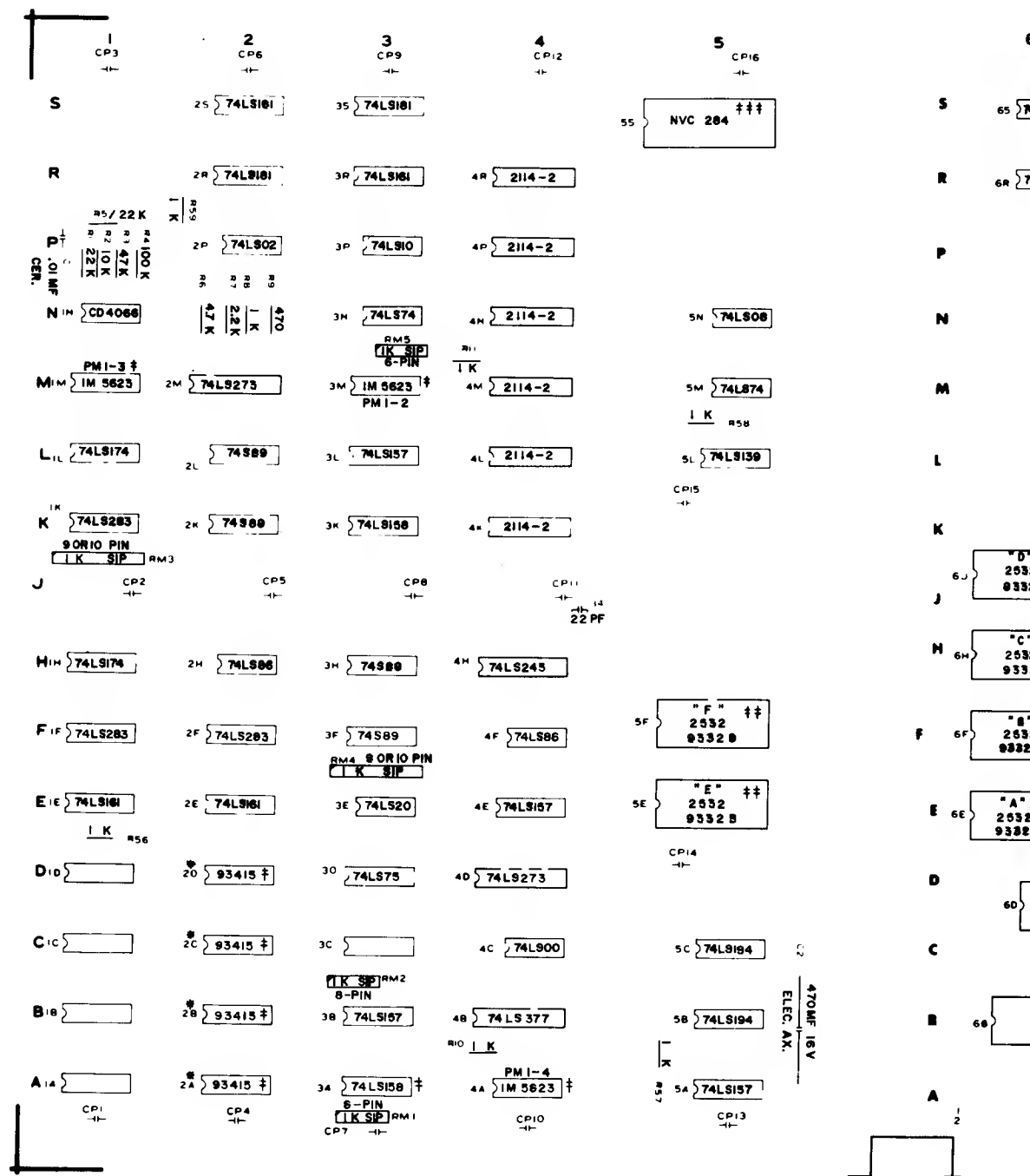

\* RAM HEAT SINK ASSEMBLY

NOTE 1: PLACE EITHER 74LS259 IN LOC. 8 K  
OR CD4099 IN LOC. 7 K

UNMARKED CAPS ARE .1MF CER. AX.  
RESISTOR UNIT = Ohm

‡ - 16 PIN SOCKET (9 PER)

‡‡ - 24 PIN SOCKET (8 PER)

‡‡‡ - 28 PIN SOCKET (2 PER)

‡‡‡‡ - 40 PIN SOCKET (1 PER)

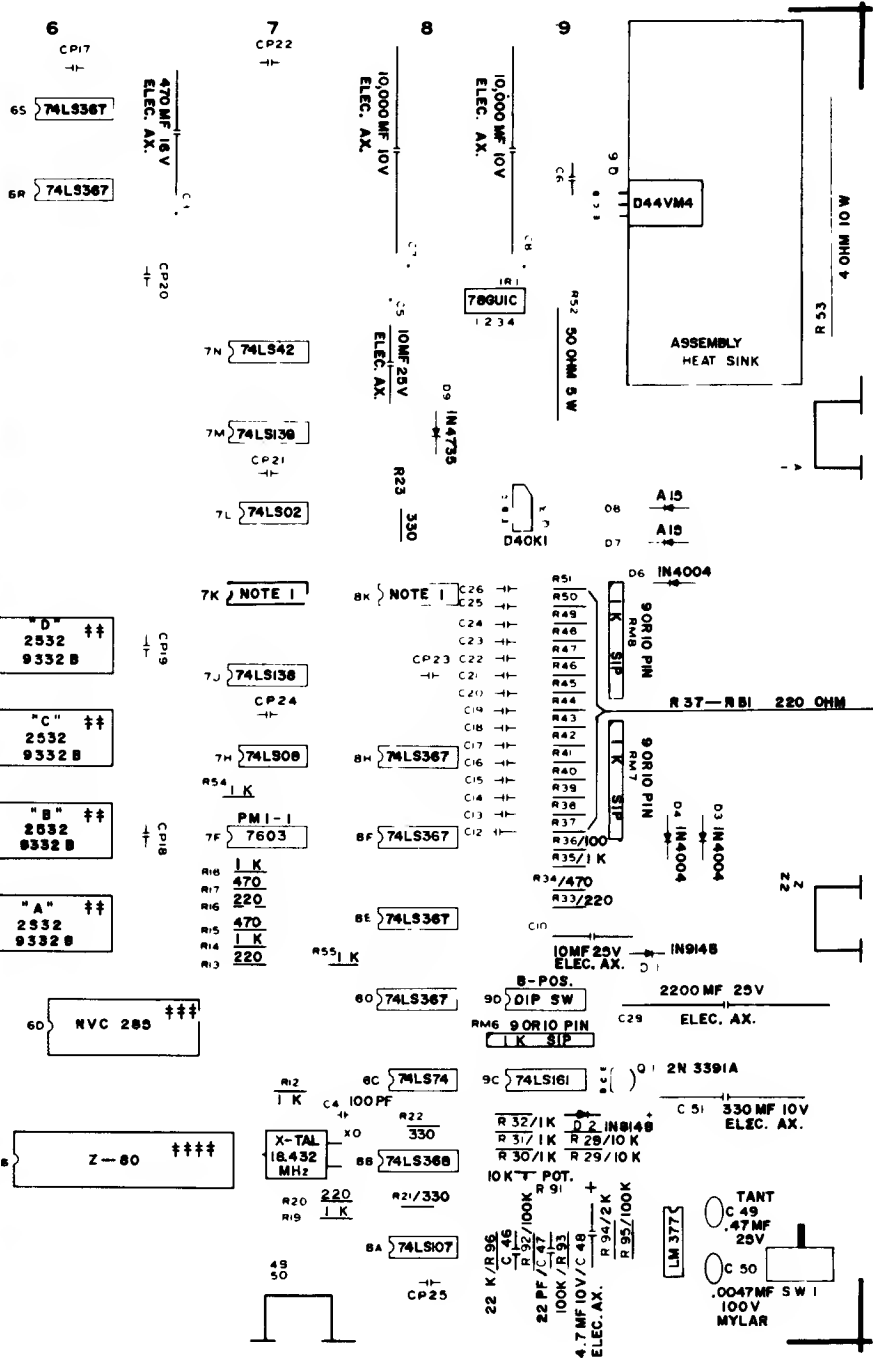

M051-00932-A026

USED ON PAC-MAN "A"

**MIDWAY MFG. CO.**  
FRANKLIN PK ILL

DO NOT SCALE DWG		HEAT TREAT	SCALE	NO RECD   PER	PART NO
DIM TOLERANCES UNLESS SPECIFIED		MAT'L	ASSEMBLY DRAWING	ASSEMBLY DRAWING	A082-91375-A000
CONVERTIBLE TO IN 100	UNN	FINISH	PAC-MAN		
FINAL FINAL 1.54	DATE 10/9/80				
UNLIM 1.005					
SCALE DIA 4.002 000					



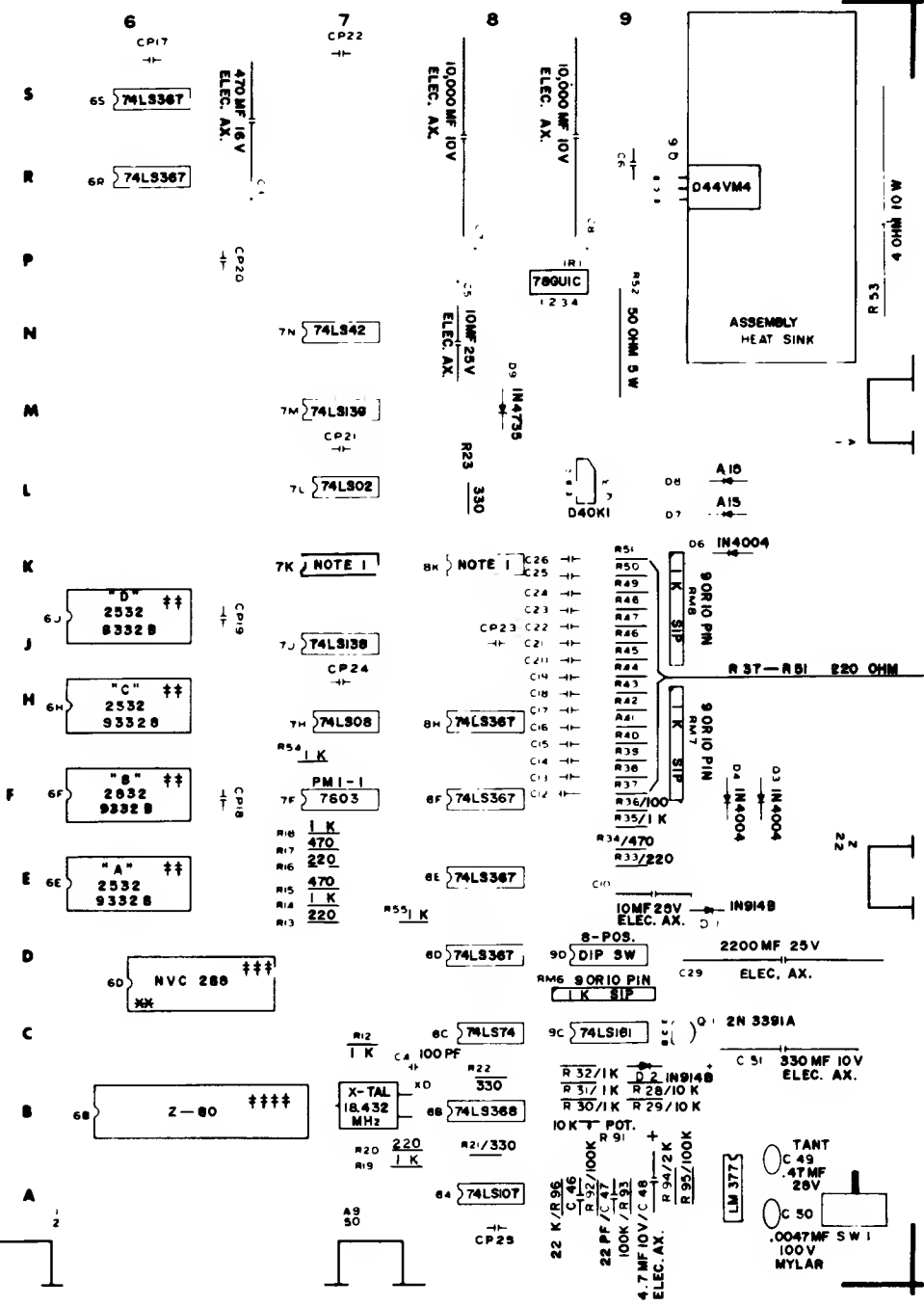

NOTE : THIS LOCATION CAN UTILIZE EITHER  
 (A) CUSTOM CHIP NVC285 OR (B) PLUG IN PC A082-91383-B000 Z-80 SYNC BUSS CONTROLLER (285)

NOTE : THIS LOCATION CAN UTILIZE EITHER  
 (A) CUSTOM CHIP NVC284 OR (B) PLUG IN PC A082-91384-B000 V-RAM ADDRESSER (284)

M051-00932-B026

USED ON PAC-MAN "B"  
 NO RECD 1 PER

MIDWAY MFG. CO.  
 FRANKLIN PK ILL

DO NOT SCALE DWG		HEAT TREAT	SCALE
DIM TOLERANCES UNLESS SPECIFIED		MAT'L	FINISH
DATE	10/9/80		

ASSEMBLY DRAWING  
 PAC-MAN

REVISIONS

NO	REV	DATE	DESCRIPTION

PART NO  
 A082-91375-B000



**GAME BOARD P.C.  
PAC - MAN  
P.C. A082 - 91375 - A000  
B000**

<b>CHIP NUMBER</b>	<b>FUNCTION</b>	<b>CHIP NUMBER</b>	<b>FUNCTION</b>
74LS00	Quad 2 input Nand	NVC284	Custom V Ram Addresser
74LS02	Quad 2 input Nor	NVC285	Custom Z80 Sync buss controller
74LS08	Quad 2 input And	CD4066	Quad bilateral switch
74LS10	Triple 3 input Nand	2114	Ram 1K x 4
74LS20	Dual 4 input Nand	1M5623	Prom 256 x 4
74LS42	BCD to decimal decoder	7603	Prom 32 x 8
74LS74	Dual "D" Flip-Flop	MCM 2532	Prom 4K x 8
74LS75	Quad latch	SL 4239	Ram 1K x 1
74LS86	Quad 2 input exclusive or	93415	Ram 1K x 1
74S89	64 Bit Ram 16 x 4	27LS00	Ram 1K x 1
74LS107	Dual "JK" Flip-Flop	MB 8125	Ram 1K x 1
74LS138	3 to 8 line decoder	CD 4099	8 bit addressable latch
74LS139	Dual 2 to 4 line decoder	N8T245	Octal bus transceiver
74LS157	Quad 2 to 1 line multiplexer	54LS174	Hex "D" Flip-Flop
74LS158	Quad 2 to 1 line multiplexer inverting	MB7052	Prom 256 x 4
74LS161	4 Bit binary counter	MB7051	Prom 32 x 8
74LS174	Hex "D" Flip-Flop	8304	Octal bus transceiver
74LS194	8 bit shift register	Additional Devices	
74LS245	Octal bus transceiver	78GVIC	Voltage regulator
74LS259	8 bit addressable latch	D44VM4	Transistor NPN
74LS273	Octal "D" Flip-Flop	D40K1	Transistor NPN
74LS283	4 Bit full adder	2N3391	Transistor NPN
74LS367	Hex bus driver	1N4004	Diode
74LS368	Hex bus driver inverting	A15	Diode
74LS377	Octal "D" Flip-Flop	1N914B	Diode
Z80	CPU	1N4737	6.2V Zener diode
LM377 - LM877	Dual audio amplifier	18.4320	Crystal

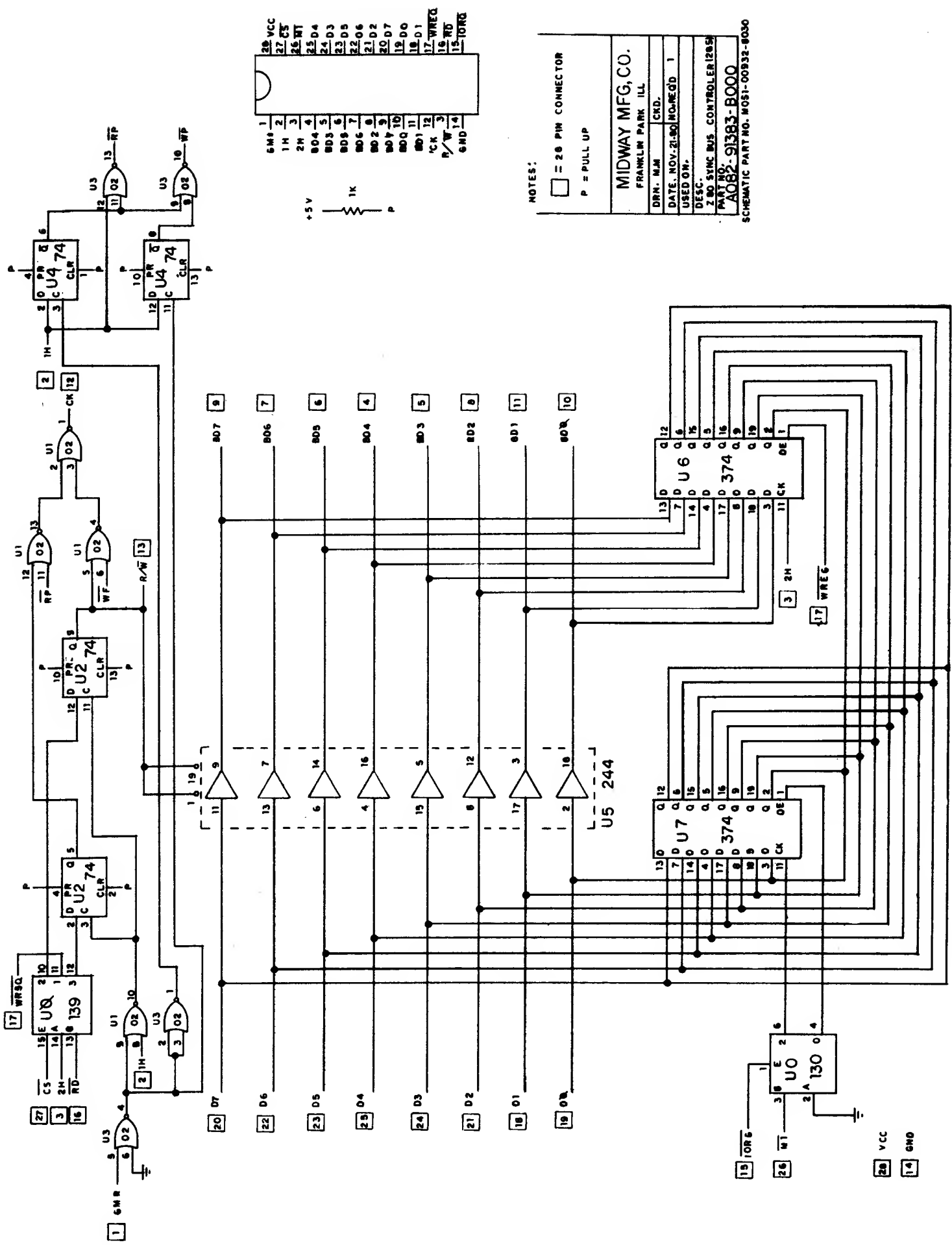

28	VCC
27	CS
26	2H
25	D4
24	D3
23	D5
22	D6
21	D2
20	D7
19	D0
18	D1
17	WREG
16	RD
15	10RQ
14	11RQ
13	12RQ
12	13RQ
11	14RQ
10	15RQ
9	16RQ
8	17RQ
7	18RQ
6	19RQ
5	20RQ
4	21RQ
3	22RQ
2	23RQ
1	24RQ
0	25RQ
26	VCC
27	CS
28	2H
29	D4
30	D3
31	D5
32	D6
33	D2
34	D7
35	D0
36	D1
37	WREG
38	RD
39	10RQ
40	11RQ
41	12RQ
42	13RQ
43	14RQ
44	15RQ
45	16RQ
46	17RQ
47	18RQ
48	19RQ
49	20RQ
50	21RQ
51	22RQ
52	23RQ
53	24RQ
54	25RQ

NOTES:

- = 28 PIN CONNECTOR
- P = PULL UP

MIDWAY MFG. CO.  
FRANKLIN PARK ILL.

DRN. M.M.	CRD.
DATE. NOV. 21. 80	NO. REQ'D 1
USED ON.	
DESC.	
Z 80 SYNC BUS CONTROLLER (28P)	
PART NO.	AO82-91383-B000

SCHEMATIC PART NO. M051-00933-B030

U0-74LS139  
 U1-74LS02  
 U2-74LS74  
 U3-74LS02  
 U4-74LS74  
 U5-74LS244  
 U6-74LS374  
 U7-74LS374

(3)-JMF 50V  
 AX. CER.

(1)-1K $\frac{1}{4}$ W RESIS.

\* MOUNTED ON  
 SOLDER SIDE

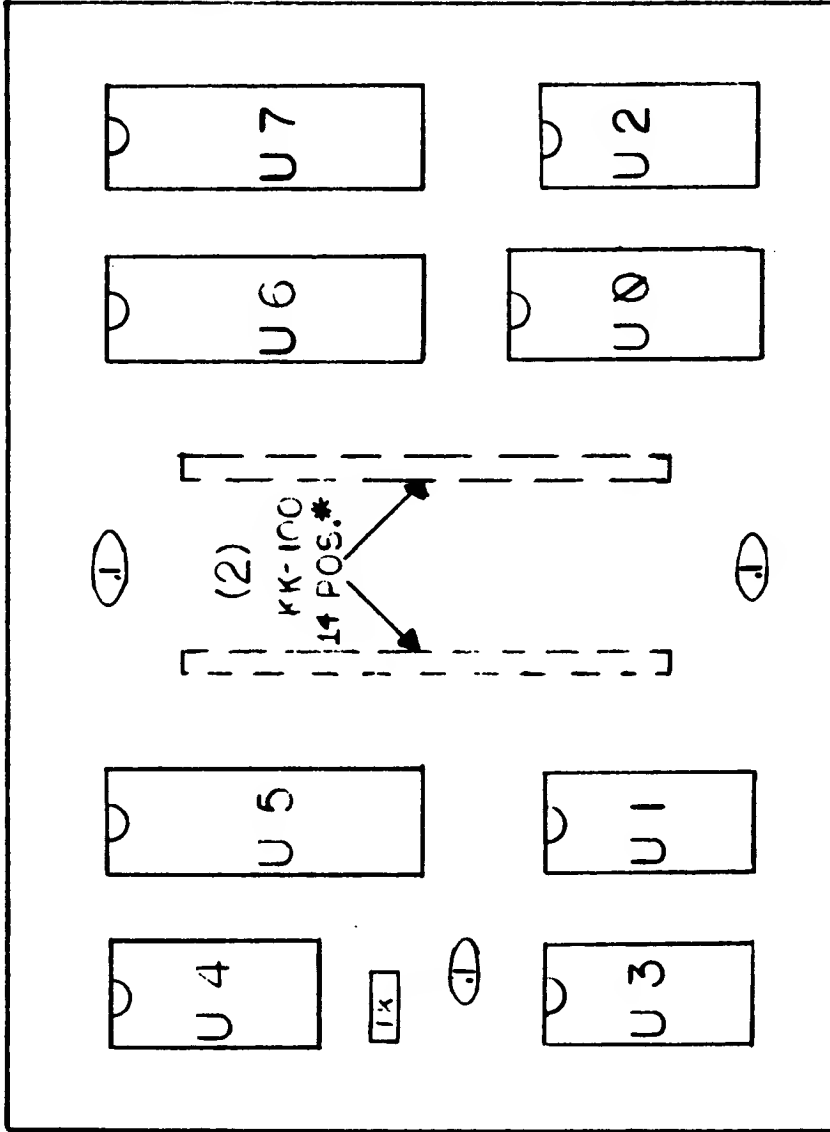

REVISIONS

MO51-00932-B031

**MIDWAY MFG. CO.**  
 FRANKLIN PK. ILL.

PART NO.

A08 2-91383 - 8000

USED ON PRC-MAM  
 NO. REQ'D 1 - PER

SCALE

HEAT TREAT

Z-80 SYNC BUSS CONTROLLER(265)

COMPONENT LAYOUT

DO NOT SCALE DWG.

DRN. M.M

DIM. TOLERANCES UNLESS SPECIFIED

FRACTIONAL ..... 1/64

DECIMAL ..... 1.000

HOLE DIA ..... ± .002-.005

MAT'L.

FINISH

DATE 10-23-80

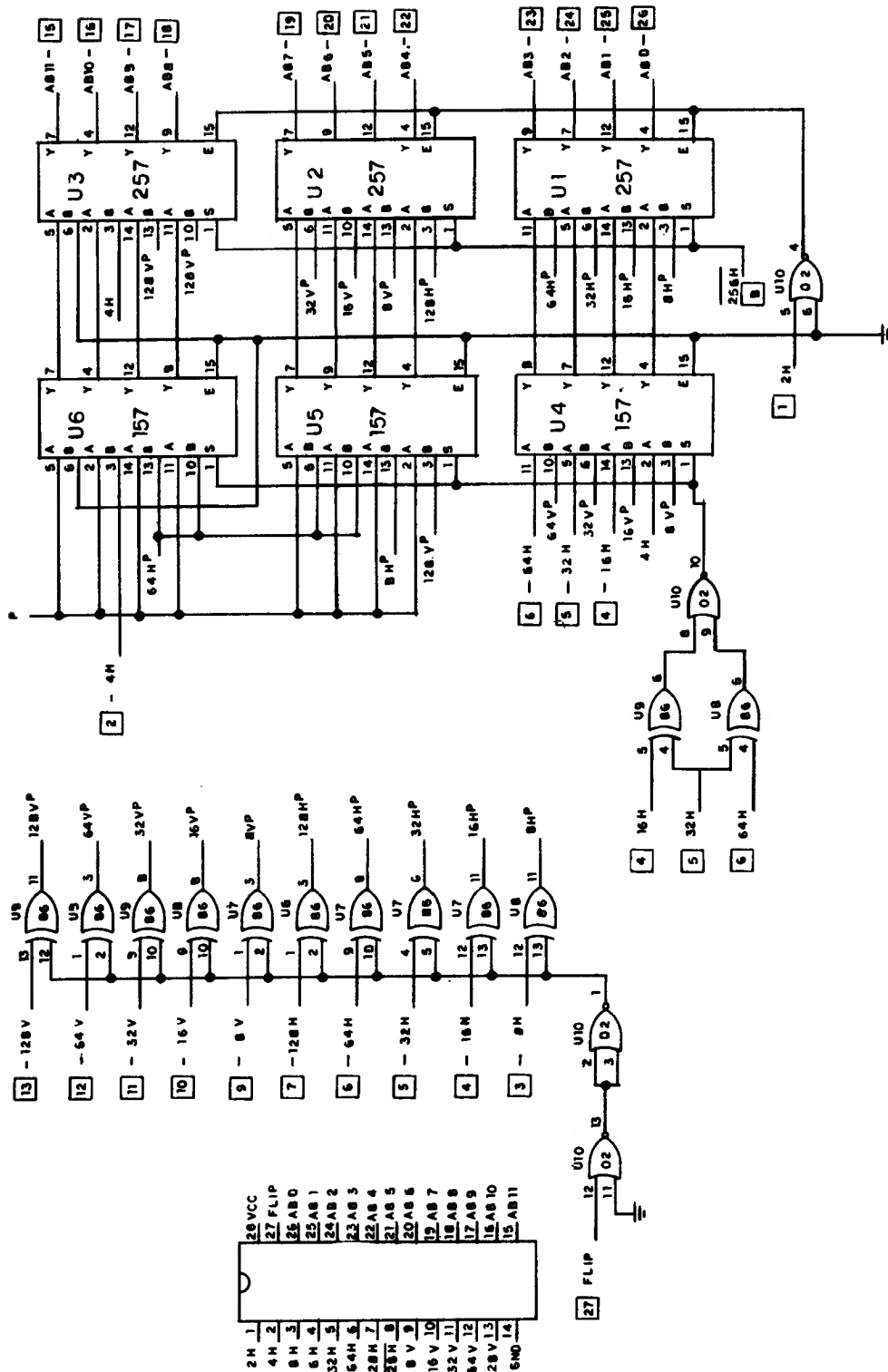

□ = 28 PIN CONNECTOR  
P = PULL UP

MIDWAY MFG. CO  
FRANKLIN PARK ILL

DRN. N.M.	CKD
DATE NOV 25 86	NO. RECD 1
USED ON	PAC - MAN
DES.	V RAM ADDRESSER (MVC-284)
PART NO.	A082-91384-B000

SCHEMATIC PART NO. M051 00932 B0 32

U1, U2, U3, 74LS257  
 U4, U5, U6, 74LS167  
 U7, U8, U9, 74LS86  
 U10 - 74LS02

.1 MF 50V - (5)  
 AX CER

1K 1/4w - (1)

(2) - 14 - POS. KK-100

\* MOUNTED ON  
 SOLDER SIDE

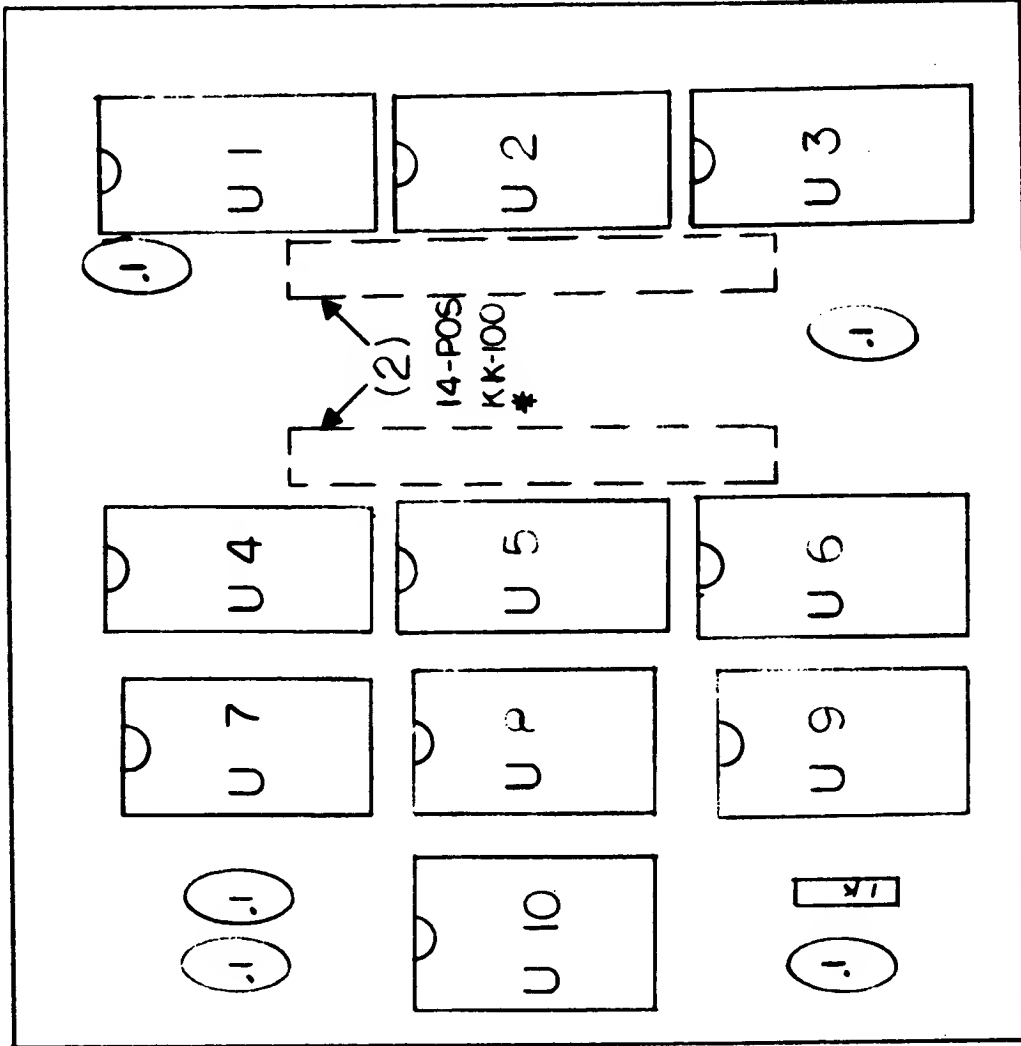

M051-00932 - 8034

REVISIONS

**MIDWAY MFG. CO.**

FRANKLIN PK. ILL.

PART NO.

A082-91384-B000

USED ON PAC-MAN

NO. REQ'D 1-PER.

SCALE

HEAT TREAT

DO NOT SCALE DWG.

V-RAM ADDRESSER (284)

COMPONENT - LAY-OUT

MAT'L.

FINISH

DIM. TOLERANCES  
 UNLESS SPECIFIED

ORN. MM  
 FRACTIONAL..... ± 1/64  
 DECIMAL..... ± .005  
 HOLE DIA..... ± .002 - .005

DATE 10-27-80

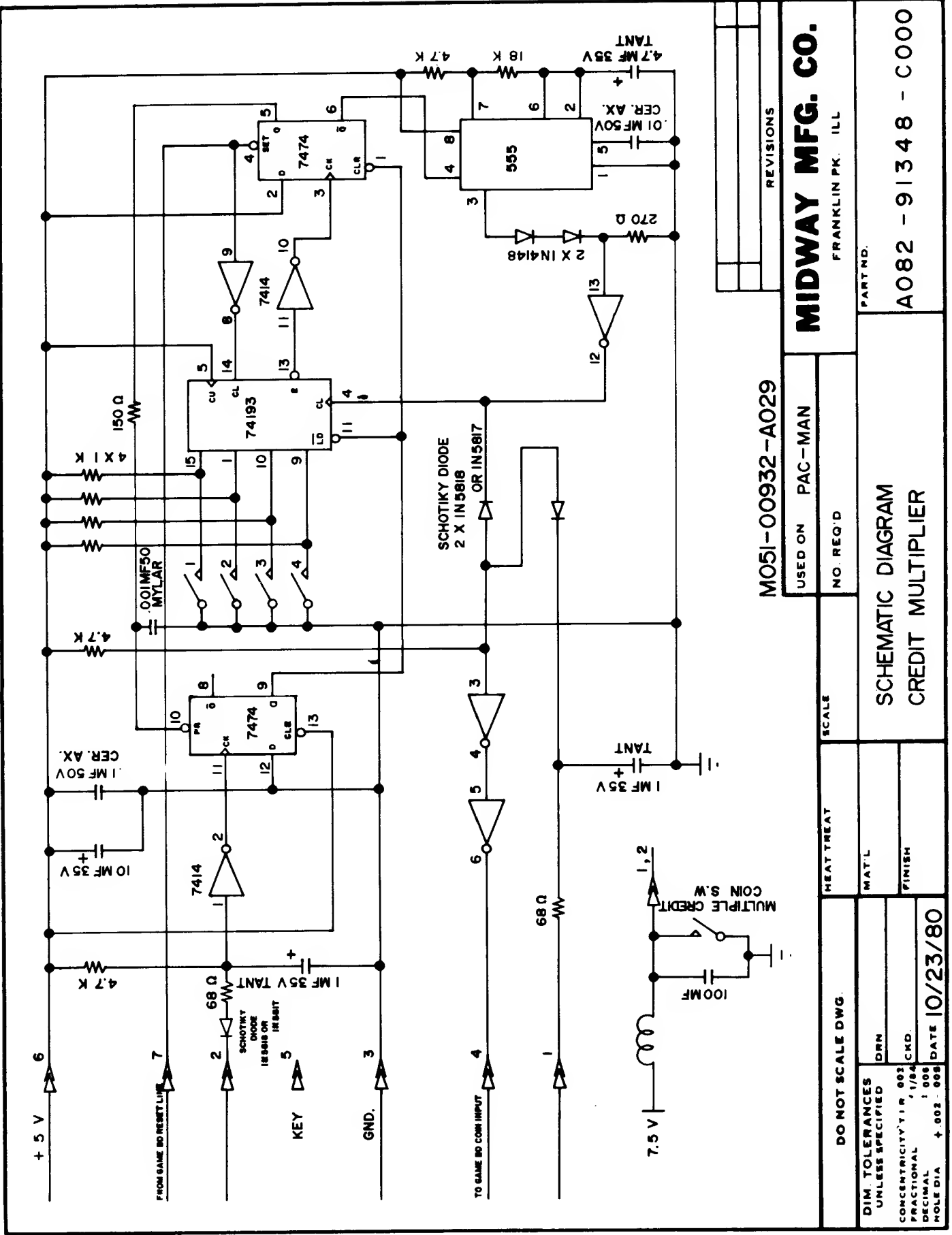

M051-00932-A029

REVISIONS

**MIDWAY MFG. CO.**  
FRANKLIN PK. ILL

USED ON PAC-MAN

NO. REQ'D

SCALE

HEAT TREAT

DO NOT SCALE DWG.

SCHEMATIC DIAGRAM  
CREDIT MULTIPLIER

MAT'L  
FINISH

DIM. TOLERANCES UNLESS SPECIFIED  
CONCENTRICITY ±.002  
FRACTIONAL DECIMAL 1/64  
HOLE DIA. ±.002 - .005  
DATE 10/23/80

PART NO.

A082 - 91348 - C000

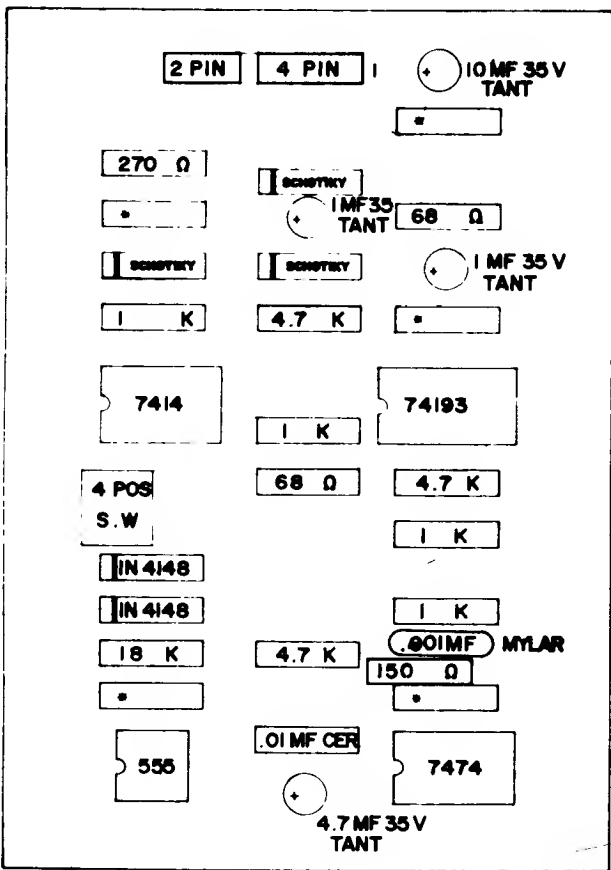

\* 1 MF 50 V . CER. AX.

SCHOTKY DIODE - IN5818 OR IN5817

M051-00932-A027

REVISIONS

**MIDWAY MFG. CO.**  
FRANKLIN PK ILL

PART NO.  
**A082-91348-C000**

USED ON **PAC-MAN**

NO REQ'D

SCALE

HEAT TREAT

DO NOT SCALE DWG.

**ASSEMBLY DRAWING**  
**CREDIT MULTIPLIER P.C**

DIM. TOLERANCES UNLESS SPECIFIED	DRN	CP
	CONCENTRICITY T.Y.R. 003	1/64 CKD
FRACTIONAL	005	
HOLE DIA.	+ 002 000	DATE 10/22/80

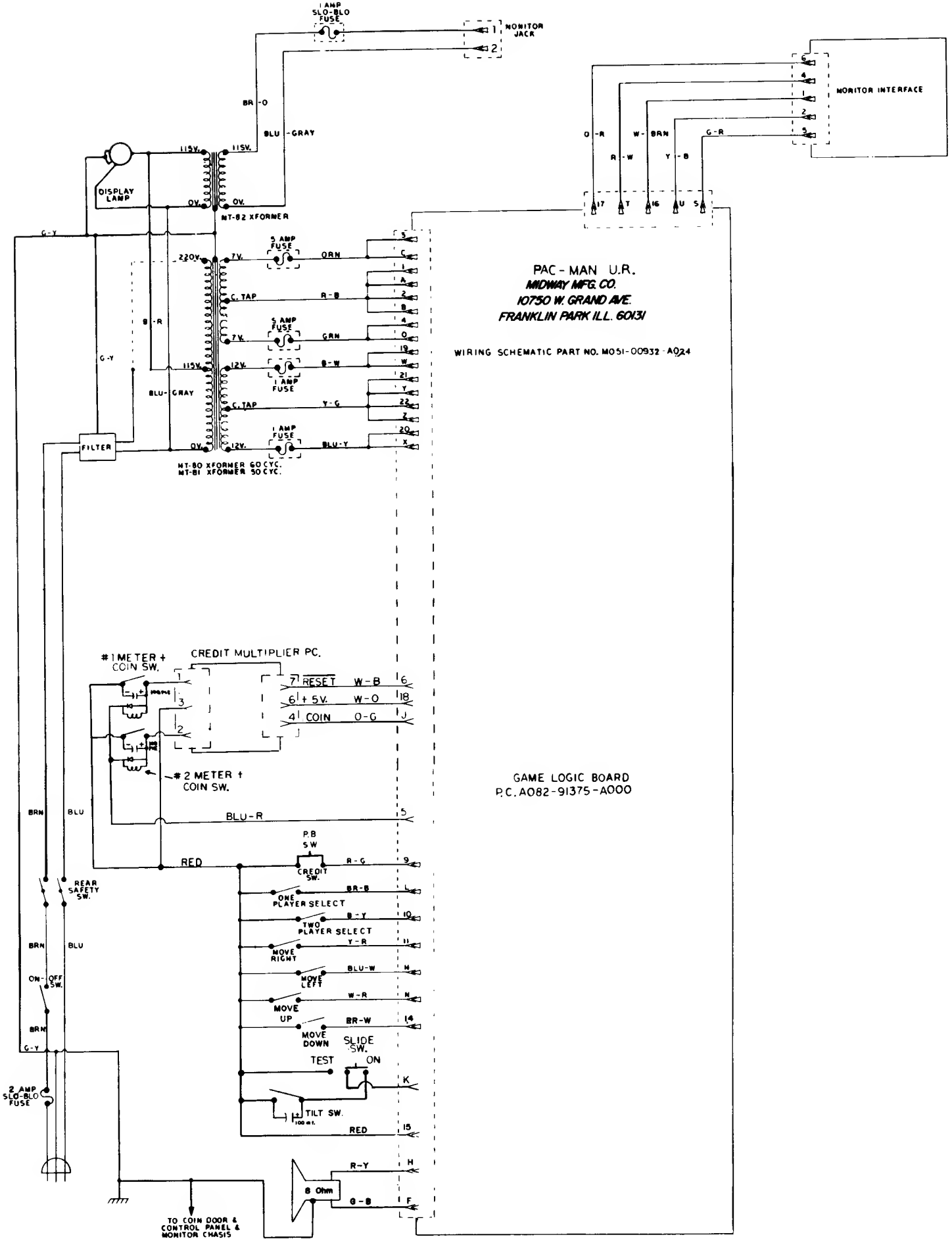



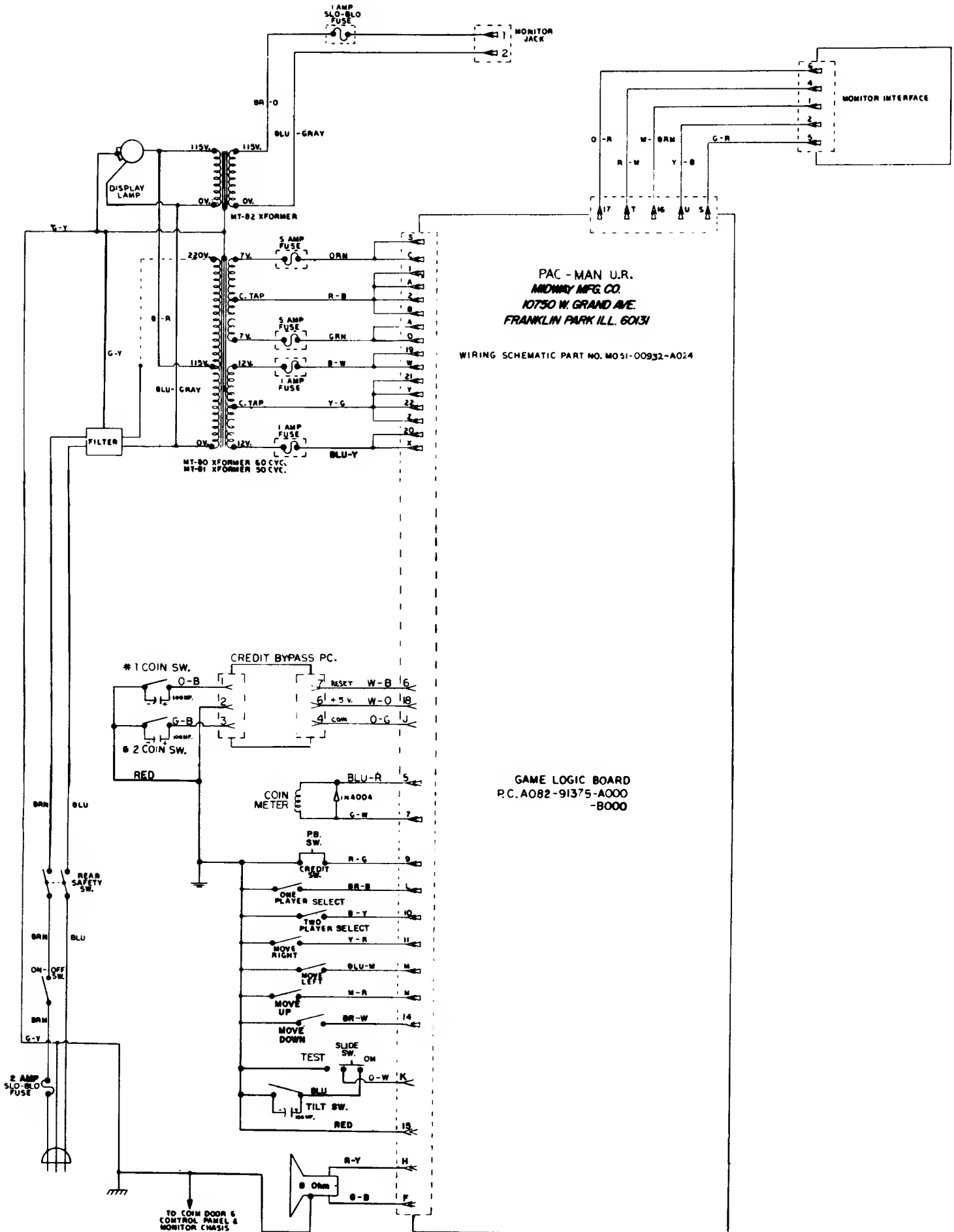

PAC-MAN U.R.  
 MIDWAY MFG. CO.  
 10750 W. GRAND AVE.  
 FRANKLIN PARK ILL. 60131

WIRING SCHEMATIC PART NO. M051-00932-A024

GAME LOGIC BOARD  
 P.C. A082-91375-A000  
 -B000

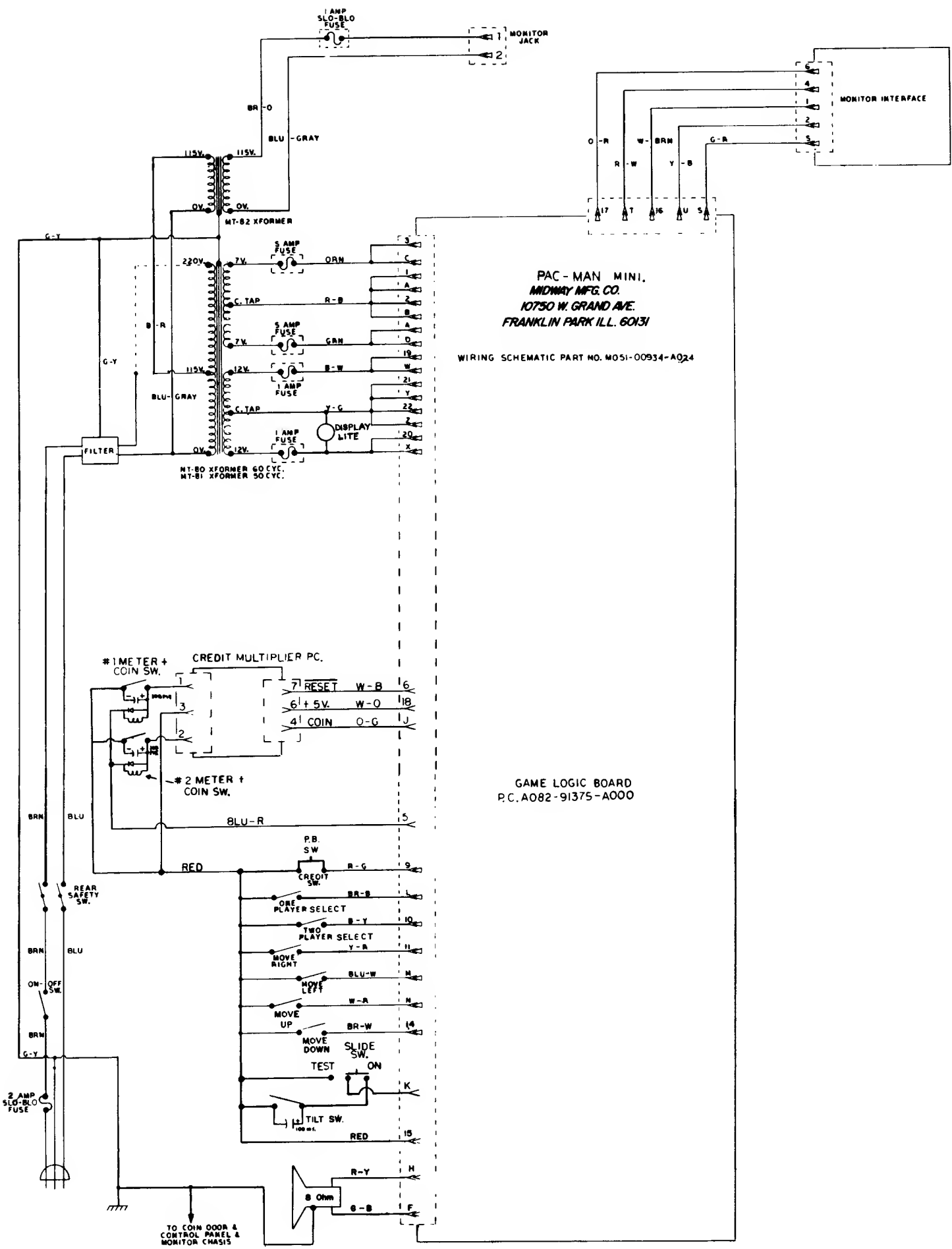

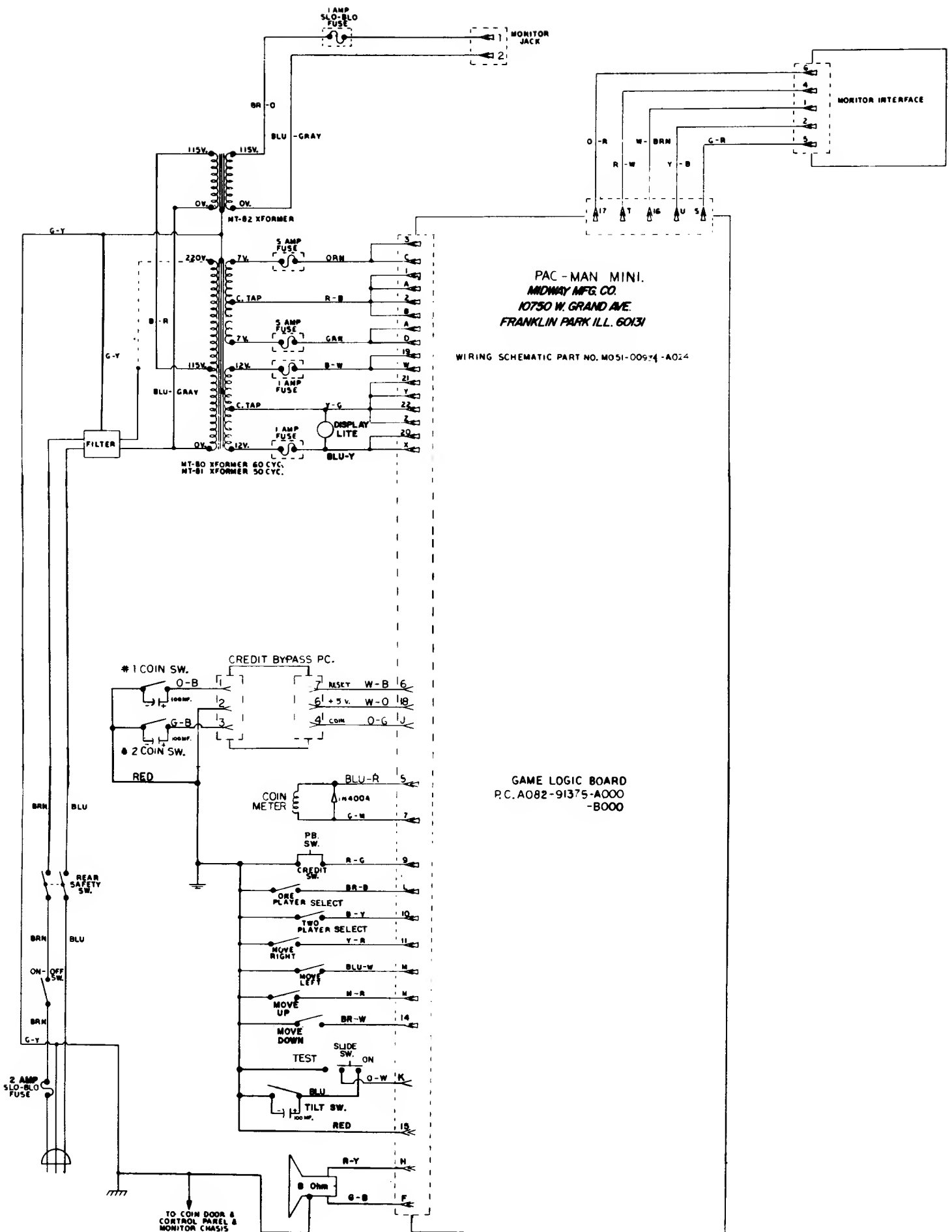

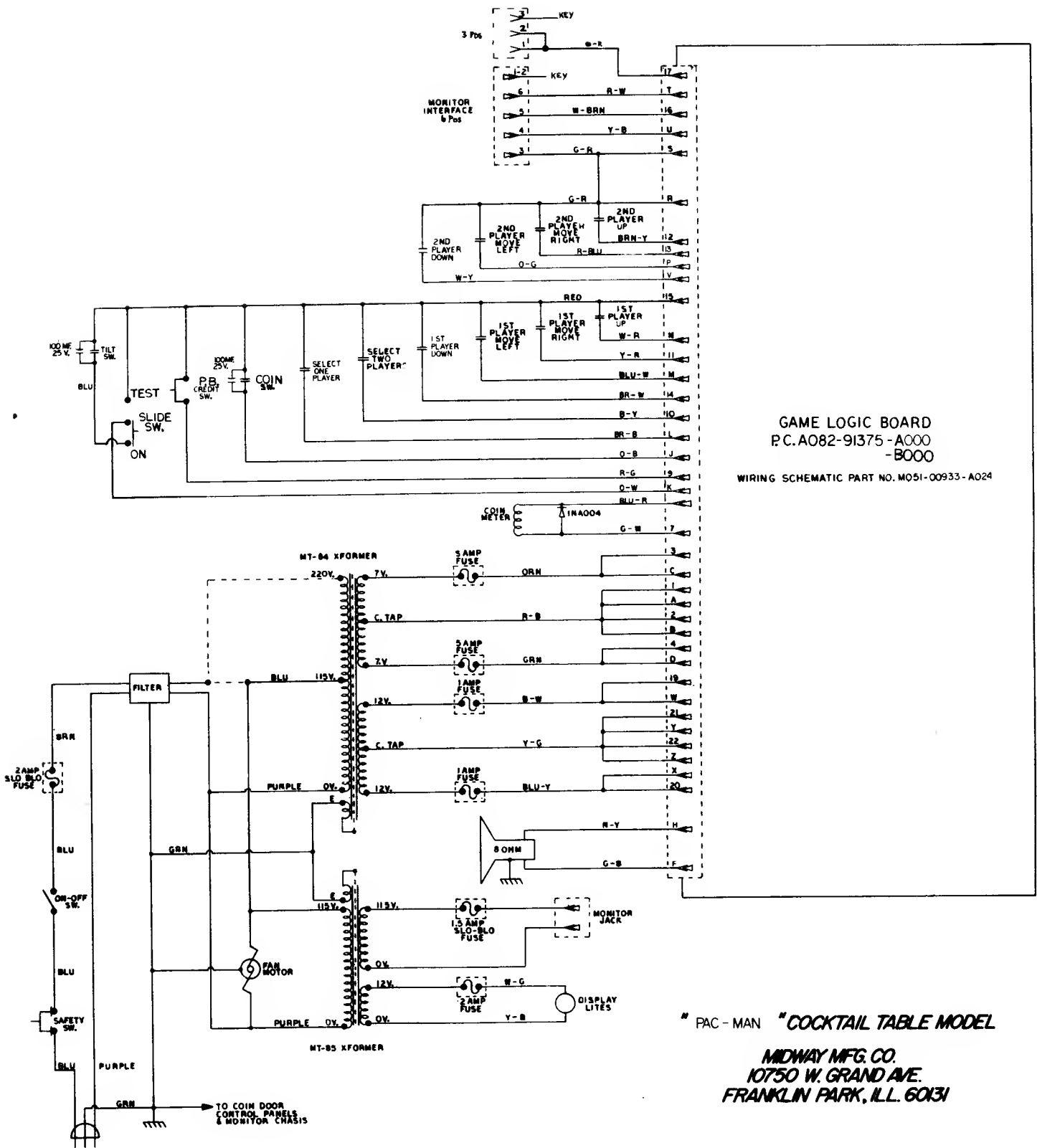

# 19" COLOR MONITOR

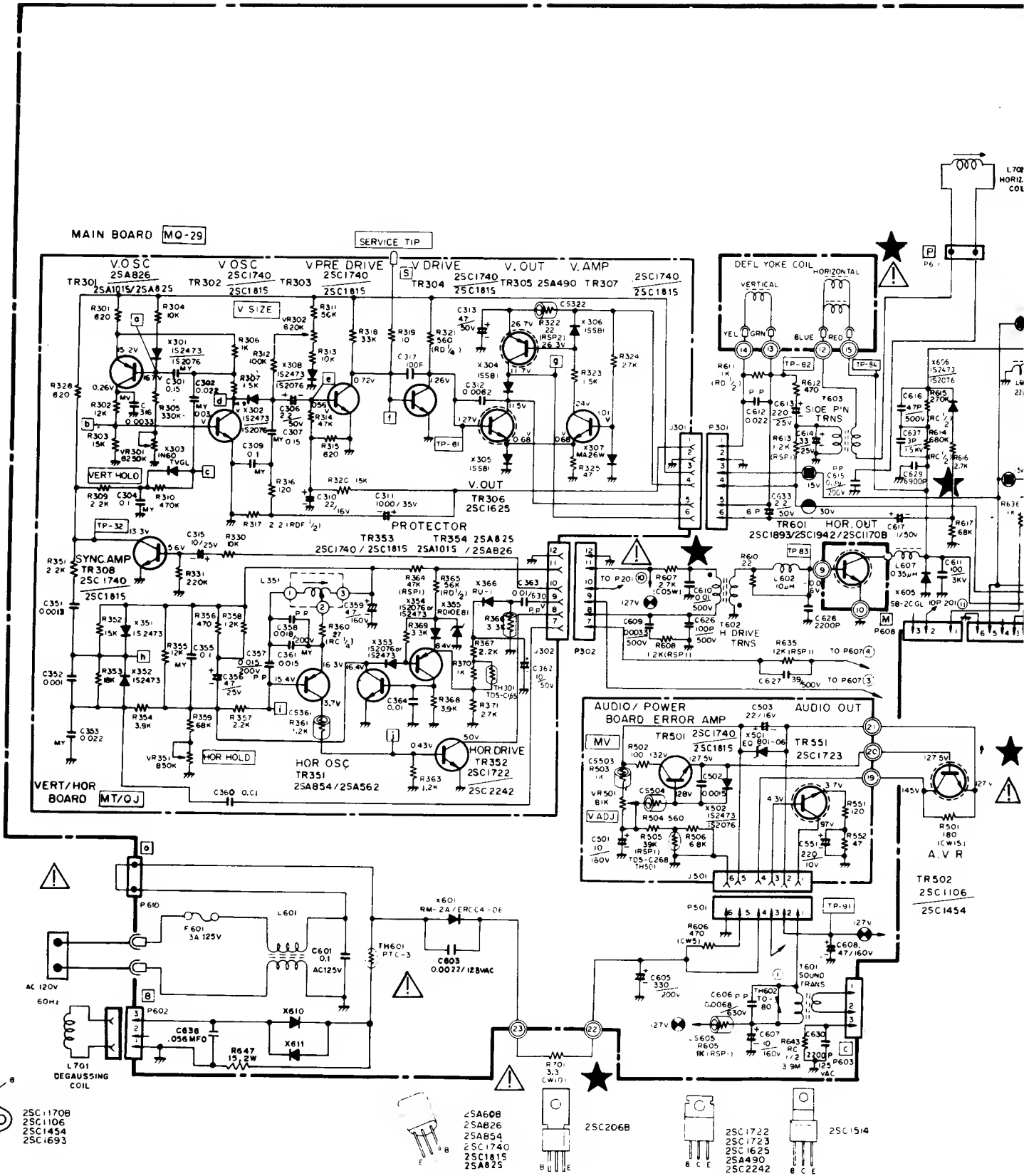

25C1170B  
 25C1106  
 25C1454  
 25C1693

25A608  
 25A826  
 25A854  
 25C1740  
 25C1815  
 25A825

25C206B

25C1722  
 25C1723  
 25C1625  
 25A490  
 25C2242

25C1514

# MONITOR SCHEMATIC DIAGRAM

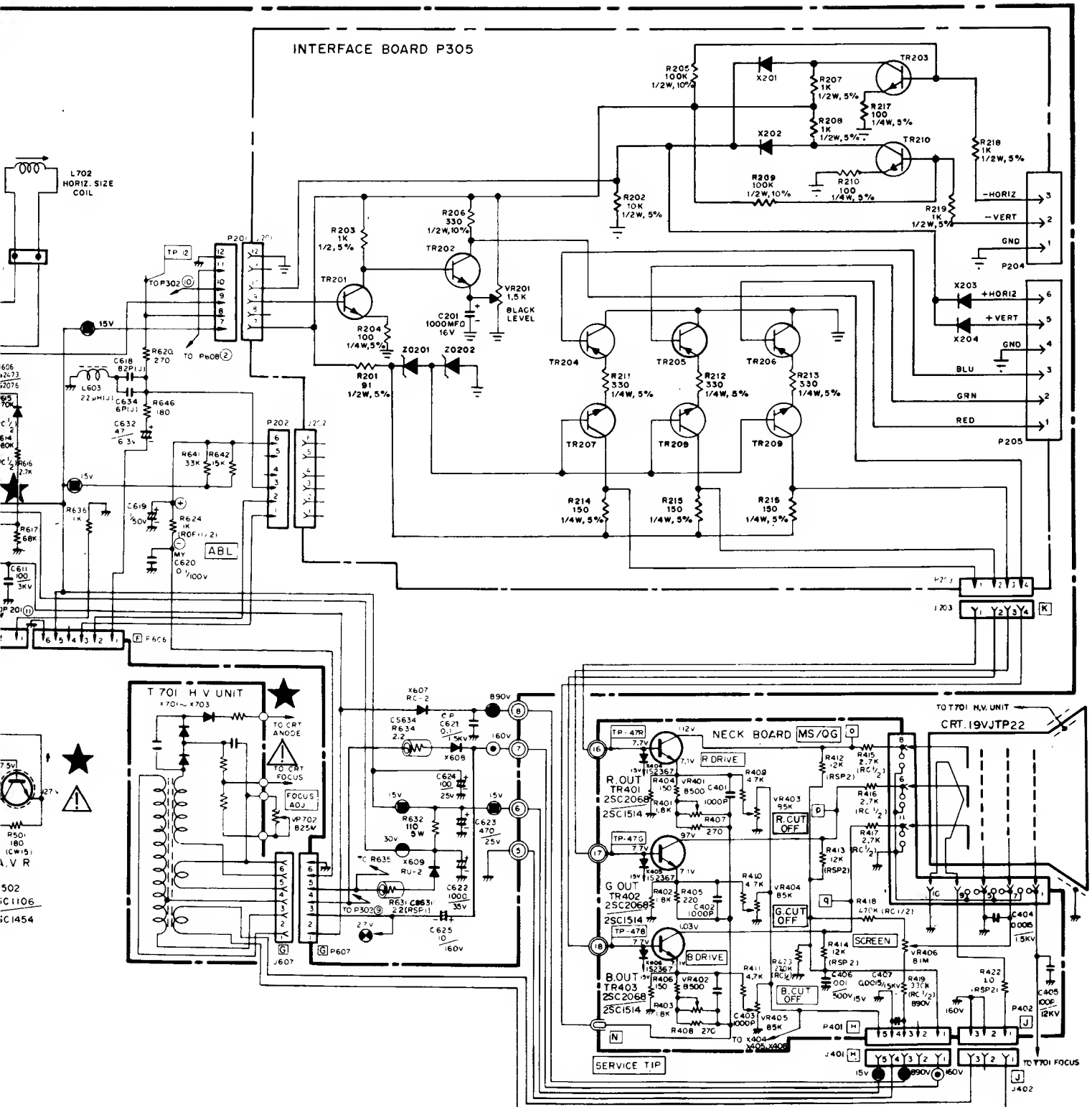

K4606-5800

# VERT/HOR BOARD (MT/QJ)

Ref. No.	Part No.	Description	Ref. No.	Part No.	Description
<b>RESISTORS</b>			<b>CAPACITORS (CONT.)</b>		
R301	203X6500-628	820 Ohm, ± 5%, 1/8W Carbon	C313	203X0025-087	47 uF, 50V Electrolytic
R302	203X6500-902	12k Ohm, ± 5%, 1/8W Carbon	C315	203X0015-082	10 uF, 25V Electrolytic
R303	203X6500-927	15k Ohm, ± 5%, 1/8W Carbon	C316	203X1100-220	3300 uF, 50V, ± 10% Mylar
R304	203X6500-886	10k Ohm, ± 5%, 1/8W Carbon	C317	202X8000-616	100 pF, 50V, ± 10% Ceramic
R305	203X6501-241	330k Ohm, ± 5%, 1/8W Carbon	C351	202X7000-281	1500 pF, 50V, ± 10% Ceramic
R306	203X6500-645	1k Ohm, ± 5%, 1/8W Carbon	C352	202X7000-247	1000 pF, 50V, ± 10% Ceramic
R307	203X6500-689	1.5k Ohm, ± 5%, 1/8W Carbon	C353	203X1100-573	0.022 uF, 50V, ± 10% Mylar
R309	203X6500-724	2.2k Ohm, ± 5%, 1/8W Carbon	C355	203X1100-858	0.1 uF, 50V, ± 10% Mylar
R310	203X6501-285	470k Ohm, ± 5%, 1/8W Carbon	C356	203X0015-105	4.7 uF, 25V Electrolytic
R311	203X6501-065	56k Ohm, ± 5%, 1/8W Carbon	C357	203X1201-013	0.015 uF, 200V ± 10% PP
R312	203X6501-126	100k Ohm, ± 5%, 1/8W Carbon	C358	203X1201-034	0.018 uF, 200V, ± 10% PP
R313	203X6001-326	10k Ohm, ± 5%, 1/8W Carbon	C359	203X0040-013	4.7 uF, 160V Electrolytic
R314	203X6501-044	47k Ohm, ± 5%, 1/8W Carbon	C360	202X7000-482	0.01 uF, 50V, ± 10% Ceramic
R315	203X6500-628	820 Ohm, ± 5%, 1/8W Carbon	C361	203X1100-509	0.015 uF, 50V, ± 10% Mylar
R316	203X6500-420	120 Ohm, ± 5%, 1/8W Carbon	C362	203X0025-058	10 uF, 50V Electrolytic
R317	203X6206-441	2.2 Ohm, ± 5%, 1/2W Carbon	C363	203X1205-487	0.01 uF, 630V, ± 10% PP
R319	203X6500-169	100 Ohm, ± 5%, 1/8W Carbon	C364	202X7000-482	0.01 uF, 50V, ± 10% Ceramic
R320	203X6500-927	15k Ohm, ± 5%, 1/8W Carbon			
R321	203X6700-509	560 Ohm, ± 5%, 1/2W Carbon			
R322	203X9100-121	22 Ohm, ± 5%, 2W M.O.			
R323	203X6500-689	1.5K Ohm, ± 5%, 1/8W Carbon			
R324	203X6500-988	27k Ohm, ± 5%, 1/8W Carbon	TR301	200X4082-614	Transistor, 2SA826Q
R325	203X6500-326	47 Ohm, ± 5%, 1/8W Carbon	TR302	200X3174-006	Transistor, 2SC1740Q
R328	203X6500-628	820 Ohm, ± 5%, 1/8W Carbon	TR303	200X3174-006	Transistor, 2SA1740Q
R330	203X6500-886	10k Ohm, ± 5%, 1/8W Carbon	TR304	200X3174-006	Transistor, 2SC1740Q
R331	203X6501-209	220k Ohm, ± 5%, 1/8W Carbon	TR305	200X4049-081	Transistor, 2SA490YLBGLI
R351	203X6500-724	2.2k Ohm, ± 5%, 1/8W Carbon	TR306	200X3162-538	Transistor, 2SC1625YLBGLI
R352	203X6500-927	15k Ohm, ± 5%, 1/8W Carbon	TR307	200X3174-014	Transistor, 2SC1740R
R353	203X6500-944	18k Ohm, ± 5%, 1/8W Carbon	TR308	200X3174-006	Transistor, 2SC1740Q
R354	203X6500-783	3.9k Ohm, ± 5%, 1/8W Carbon	TR351	200X4085-415	Transistor, 2SA854Q
R355	203X6500-902	12k Ohm, ± 5%, 1/8W Carbon	TR352	200X3172-208	Transistor, 2SC1722BKS
R356	203X6500-561	470 Ohm, ± 5%, 1/8W Carbon	TR353	200X3174-006	Transistor, 2SC1740Q
R357	203X6500-724	2.2k Ohm, ± 5%, 1/8W Carbon	TR354	200X4082-614	Transistor, 2SA826Q
R358	203X6500-666	1.2k Ohm, ± 5%, 1/8W Carbon	X301	201X2010-144	Diode, (SI) IS2473-T72
R359	203X6501-088	68k Ohm, ± 5%, 1/8W Carbon	X302	201X2010-144	Diode, (SI) IS2473-T72
R360	203X5500-471	27 Ohm, ± 5%, 1/4W Comp.	X303	200X8000-026	Diode, (GE), IN60TVGL
R361	203X6000-998	1.2k Ohm, ± 5%, 1/8W Carbon	X304	200X8010-165	Diode (SI) ISS81
R363	203X6500-666	1.2k Ohm, ± 5%, 1/8W Carbon	X305	201X2010-165	Diode (SI) ISS81
R364	203X9014-988	47k Ohm, ± 5%, 1W M.O.	X306	201X2010-165	Diode (SI) ISS81
R365	203X6700-989	56k Ohm, ± 5%, 1/2W Carbon	X307	200X8010-102	Diode (SI) MA26W
R366	203X6001-148	3.3k Ohm, ± 5%, 1/8W Carbon	X308	200X8010-094	Diode (SI) IS2473
R367	340X2222-734	2.2k Ohm, ± 5%, 1/2W Carbon	X351	201X2010-144	Diode (SI) IS2473-T72
R368	203X6500-785	3.9k Ohm, ± 5%, 1/8W Carbon	X352	201X2010-144	Diode (SI) IS2473-T72
R369	203X6500-762	3.3k Ohm, ± 5%, 1/4W Carbon	X353	201X2010-144	Diode (SI) IS2473-T72
R370	302X6100-961	1k Ohm, ± 5%, 1/4W Carbon	X354	201X2010-144	Diode (SI) IS2473-T72
R371	203X6104-751	2.7k Ohm, ± 5%, 1/4W Carbon	X355	200X8220-851	Diode (Zener) RD10EBI
VR301	204X2122-093	Varistor, 250K Ohm, Vert. Hold	X366	200X8100-130	Diode (HS) RU-1 0.3 US
VR302	204X2114-065	Varistor, 20K Ohm, Vert. Size			
VR351	204X2114-059	Varistor, 50K Ohm, Hor. Hold			

## SEMICONDUCTORS

## MISCELLANEOUS

Ref. No.	Part No.	Description	Ref. No.	Part No.	Description
C301	203X1100-928	0.15 uF, 50V, ± 10% Mylar	J301	204X9300-958	Socket, 6 Pin
C302	203X1100-573	0.022 uF, 50V, ± 10% Mylar	J302	204X9300-958	Socket, 8 Pin
C304	203X1100-858	0.1 uF, 50V, ± 10% Mylar	P301	204X9601-195	Plug, 6 Pin
C306	203X0025-026	2.2 uF, 50V, Electrolytic	P302	204X9601-195	Plug, 8 Pin
C307	203X1100-928	0.15 uF, 50V, ± 10% Mylar	TH301	201X0000-534	Thermistor
C309	203X1100-858	0.1 uF, 50V, ± 10% Mylar			
C310	203X0010-011	22 uF, 16V Electrolytic			
C311	203X0020-099	1000 uF, 35V Electrolytic			
C312	202X7000-469	0.0082 uF, 50V, ± 10% Ceramic	L351	201X5200-091	Coll, Horiz. Osc.

## TRANSFORMERS & COILS

# POWER BOARD (MV)

Ref. No.	Part No.	Description	Ref. No.	Part No.	Description
<b>RESISTORS</b>			<b>SEMICONDUCTORS</b>		
R501	204X1725-052	180 Ohm, ± 10%, 15W WW	TR501	200X3174-006	Transistor, 2SC1740Q
R502	203X6000-608	100 Ohm, ± 5%, 1/8W Carbon	★ TR502	200X3145-404	Transistor, 2SC1454
R503	203X6000-960	1k Ohm, ± 5%, 1/8W Carbon	TR551	200X3172-305	Transistor, 2SC1723
R504	203X6000-879	560 Ohm, ± 5%, 1/8W Carbon	X501	201X2230-042	Diode, (SI) Zener EQB01-06V
R505	203X9014-965	39k Ohm, ± 5%, 1W M.O.	X502	201X2010-144	Diode, (SI) IS2473-T72
R506	203X6500-842	6.8k Ohm, ± 5%, 1/8W Carbon			
R551	203X6500-420	120 Ohm, ± 5%, 1/8W Carbon			
VR501	204X2050-001	Varistor Vert. Adj.			
<b>CAPACITORS</b>			<b>MISCELLANEOUS</b>		
C501	203X0040-020	10 uF, 160V Electrolytic	J501	204X9300-958	Socket, 6 Pin
C502	202X7000-281	1500 pF, 50V, ± 10% Ceramic	P501	204X9601-195	Plug, 6 Pin
			TH501	201X0000-618	Thermistor

# NECK BOARD (MS/QG)

Ref. No.	Part No.	Description	Ref. No.	Part No.	Description
<b>RESISTORS</b>					
R401	203X6500-709	1.8k Ohm ± 5% 1/8W Carbon	C403	202X7000-247	1000 pF, 50V, 10% Ceramic
R402	203X6500-709	1.8k Ohm ± 5% 1/8W Carbon	C404	202X7110-019	1500 pF, 2kV ± 10% Ceramic
R403	203X6500-709	1.8k Ohm ± 5% 1/8W Carbon	C405	202X7150-018	100 pF, 12kV, ± 10% Ceramic
R404	203X6500-447	150 Ohm ± 5% 1/8W Carbon	C406	202X7050-483	.01 uF, 500V, ± 10% Ceramic
R405	203X6500-481	220 Ohm ± 5% 1/8W Carbon	C407	202X7110-019	1500 pF, 2kV ± 10% Ceramic
R406	203X6500-447	150 Ohm ± 5% 1/8W Carbon	C408	202X8000-550	88 pF, 50V, ± 10% Ceramic
R407	203X6500-508	270 Ohm ± 5% 1/8W Carbon	C409	202X8000-550	68 pF, 50V, ± 10% Ceramic
R408	203X6500-508	270 Ohm ± 5% 1/8W Carbon	C410	202X8000-550	68 pF, 50V, ± 10% Ceramic
R409	203X6500-800	4.7k Ohm ± 5% 1/8W Carbon	<b>SEMICONDUCTORS</b>		
R410	203X6500-800	4.7k Ohm ± 5% 1/8W Carbon			
R411	203X6500-800	4.7k Ohm ± 5% 1/8W Carbon			
R412	203X9104-809	12k Ohm ± 5% 2.0W Metal Oxide			
R413	203X9104-809	12k Ohm ± 5% 2.0W Metal Oxide			
R414	203X9104-809	12k Ohm ± 5% 2.0W Metal Oxide			
R415	203X5601-313	2.7k Ohm ± 10% 1/2W Comp.	TR401	200X3206-800	Transistor, 2SC2068, 2SC1514 (R output)
R416	203X5601-313	2.7k Ohm ± 10% 1/2W Comp.	TR402	200X3206-800	Transistor, 2SC2068, 2SC1514 (G output)
R417	203X5601-313	2.7k Ohm ± 10% 1/2W Comp.	TR403	200X3206-800	Transistor, 2SC2068, 2SC1514 (B output)
R418	203X5602-254	470k Ohm ± 10% 1/2W Comp.			
R419	203X5602-185	330k Ohm ± 10% 1/2W Comp.			
R422	203X9105-117	1.0 Ohm ± 10% 2W Metal Oxide			
R423	203X5102-155	270k Ohm ± 5% 1/4W Carbon	X404	201X2100-126	Diode, IS2367 (protector)
VR401	204X2115-014	500 Ohm Varistor R Drive	X405	201X2100-126	Diode, IS2367 (protector)
VR402	204X2115-014	500 Ohm Varistor B Drive	X406	201X2100-126	Diode, IS2367 (protector)
VR403	204X2115-006	5k Ohm Varistor R Cutoff			
VR404	204X2115-006	5k Ohm Varistor G Cutoff			
VR405	204X2115-006	5k Ohm Varistor B Cutoff			
VR406	204X2000-025	1M Ohm Varistor Screen			

<b>CAPACITORS</b>			<b>MISCELLANEOUS</b>		
C401	202X7000-247	1000 pF, 50V, 10% Ceramic	J401	206X5003-729	Socket, 5 Pin
C402	202X7000-247	1000 pF, 50V, 10% Ceramic	J402	206X5003-983	Socket, 3 Pin
			P401	204X9600-329	Plug, 5 Pin
			P402	204X9600-254	Plug, 3 Pin

## ★ 297X2000-072 HIGH VOLTAGE ASSEMBLY (T701)

★ R701	204X1625-058	3.3 Ohm, ± 10% 10W WW Resistor	} Part of T701
★ VR702	204X3901-125	Focus Control	
X701		Diode (Si HV)	
X702		Diode (Si HV)	
X703		Diode (Si HV)	

## FINAL ASSEMBLY PARTS

★ 88X-0129-506	19VJTP22 Plx Tube
38A5554-000	Assy. Purity Shld/Degaussing
205X9800-256	Lateral/Purity Assembly
★ 202X1110-810	Yoke, Deflection
208X2000-946	CRT Socket
297X2000-072	HV Unit (T701)
6A0397	Plug, Line Cord
9A2753-003	Degaussing Coil (L701)

## INTERFACE BOARD (P305) (MODEL 19K4606)

<b>RESISTORS</b>			<b>SEMICONDUCTORS</b>		
R201	340X3910-934	91 Ohm, 5%, 1/2W Carbon	TR201	86X0121-001	Transistor (NPN)
R203	340X3102-934	1k Ohm, 5%, 1/2W Carbon	TR202	86X0121-001	Transistor (NPN)
R204	340X2101-934	100 Ohm, 5%, 1/4W Carbon	TR203	86X0121-001	Transistor (NPN)
R206	340X3331-944	330 Ohm, 10%, 1/2W Carbon	TR204	86X0066-001	Transistor (PNP)
R207	340X3102-934	1k Ohm, 5%, 1/2W Carbon	TR205	86X0066-001	Transistor (PNP)
R208	340X2152-934	1.5k Ohm, 5%, 1/4W Carbon	TR206	86X0066-001	Transistor (PNP)
R209	340X2101-934	100 Ohm, 5%, 1/4W Carbon	TR207	86X0121-001	Transistor (NPN)
R210	340X3102-934	1k Ohm, 5%, 1/2W Carbon	TR208	86X0121-001	Transistor (NPN)
R211	340X2331-934	330 Ohm, 5%, 1/4W Carbon	TR209	86X0121-001	Transistor (NPN)
R212	340X2331-934	330 Ohm, 5%, 1/4W Carbon	ZD201	66X0040-018	Diode, Zener, 6.8v, 5%, 0.5W
R213	340X2331-934	330 Ohm, 5%, 1/4W Carbon	ZD202	66X0040-019	Diode, Zener, 3.9v, 5%, 0.5W
R214	340X2201-934	200 Ohm, 5%, 1/4W Carbon			
R215	340X2201-934	200 Ohm, 5%, 1/4W Carbon			
R216	340X2201-934	200 Ohm, 5%, 1/4W Carbon			
VR201	40X0590-017	1.5k Ohm, Black Level Control			
<b>CAPACITORS</b>			<b>MISCELLANEOUS</b>		
C201	45X0524-038	1000 uF, 16V Electrolytic	J201	204X9300-958	Socket, 6 Pin
			J202	204X9300-958	Socket, 6 Pin
			J203	206X5019-207	Socket, 4 Pin
			P201	204X9601-195	Plug, 6 Pin
			P202	204X9601-195	Plug, 6 Pin
			P203	204X9600-845	Plug, 4 Pin
			P205	6A0393-006	Plug, 6 Pin



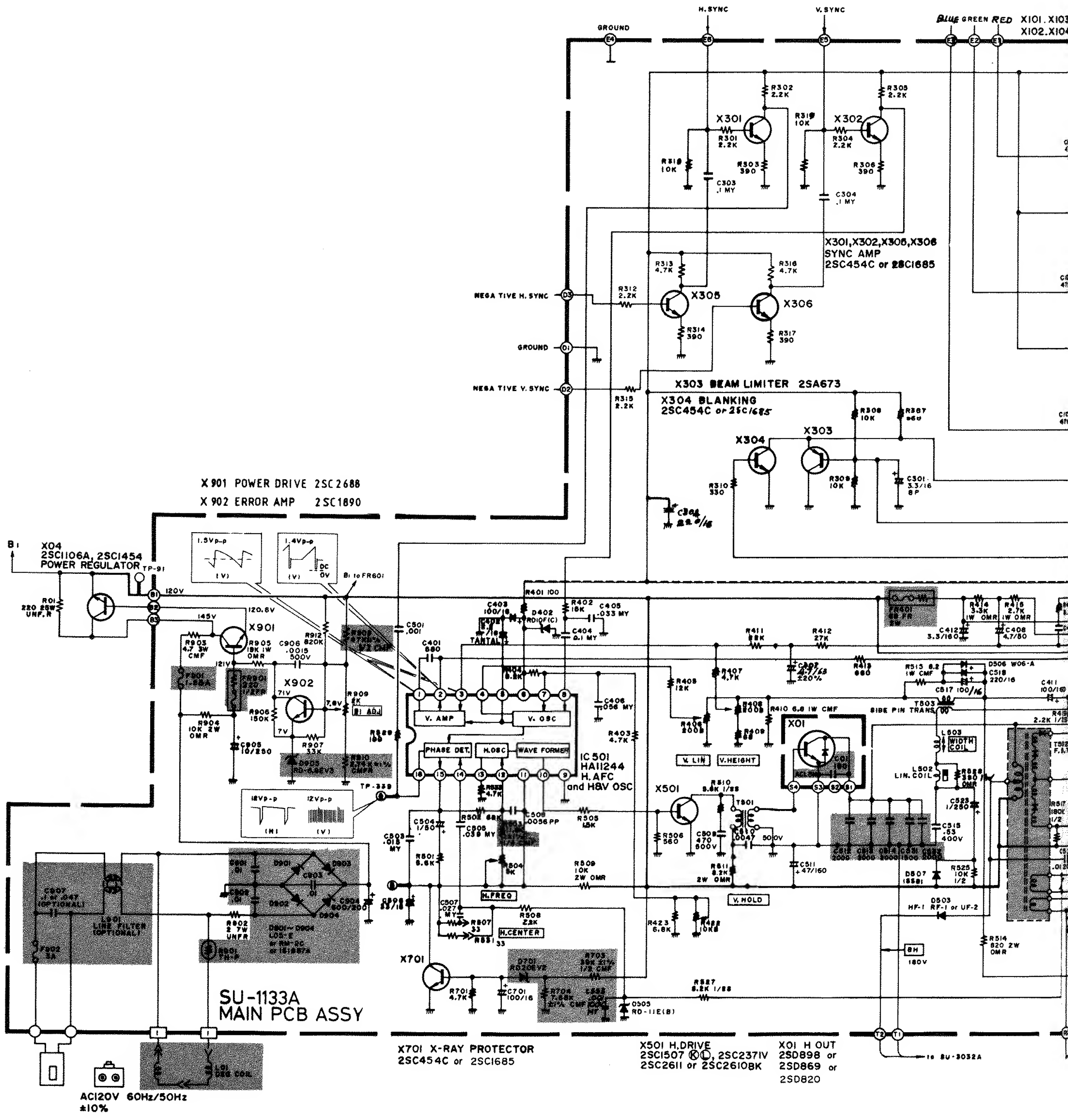

X901 POWER DRIVE 2SC2688  
X902 ERROR AMP 2SC1890

X04 2SC1106A, 2SC1454  
POWER REGULATOR

X701 X-RAY PROTECTOR  
2SC454C or 2SC1685

X501 H.DRIVE  
2SC1507, 2SC237IV,  
2SC2611 or 2SC2610BK

X01 H OUT  
2SD898 or  
2SD869 or  
2SD820

SU-1133A  
MAIN PCB ASSY

AC120V 60Hz/50Hz  
±10%

X101, X103 and X105 VIDEO AMP, 2SC454C  
 X102, X104 and X106 VIDEO AMP, 2SA673C

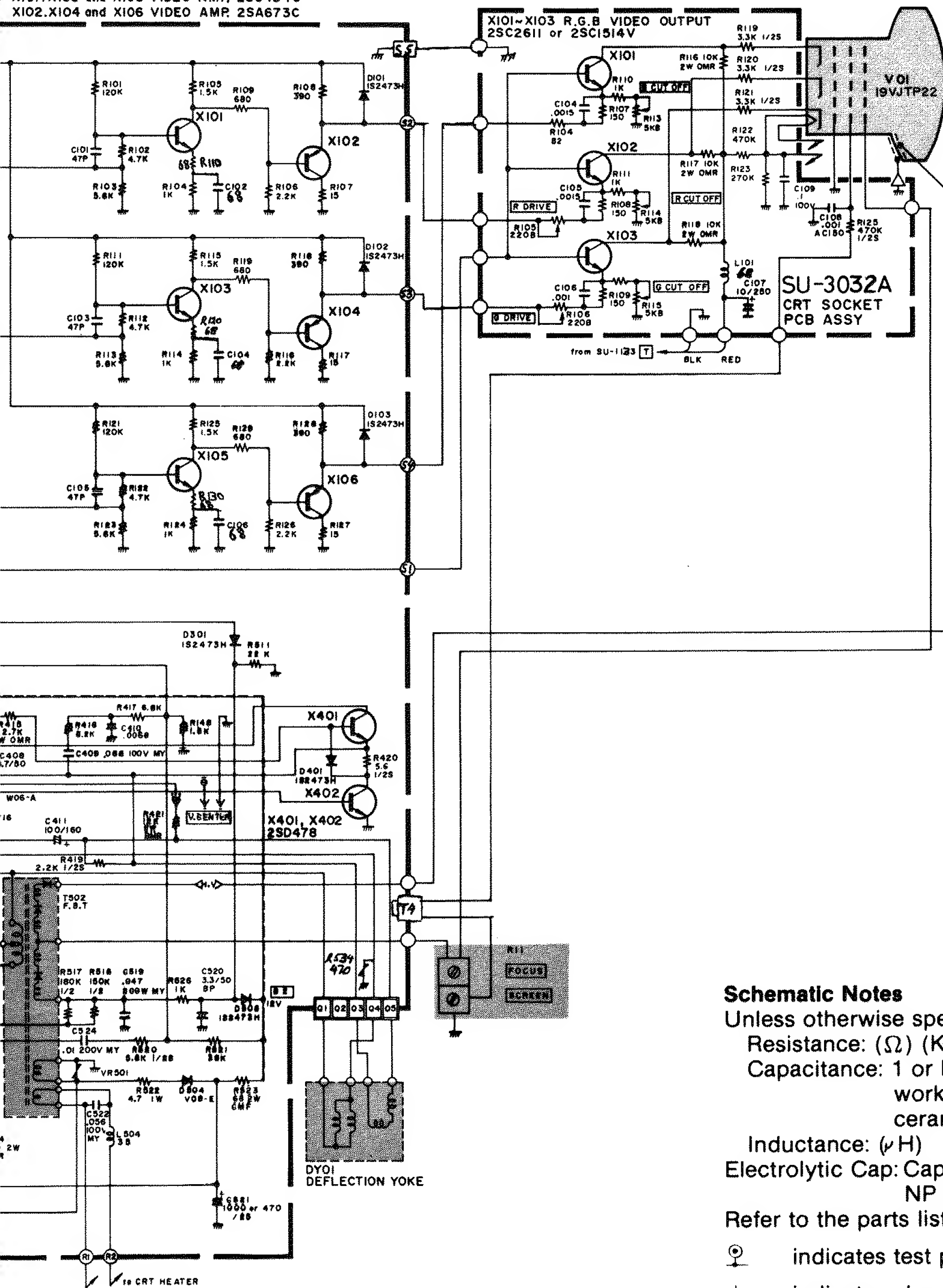

### Schematic Notes

Unless otherwise specified

Resistance: ( $\Omega$ ) (K $\rightarrow$ K $\Omega$ , M $\rightarrow$ M $\Omega$ ), 1/4 (W) carbon resistor

Capacitance: 1 or higher  $\rightarrow$  (pF), less than 1  $\rightarrow$  ( $\mu$ F)

working voltage  $\rightarrow$  50 (V)

ceramic capacitor

Inductance: ( $\mu$ H)

Electrolytic Cap: Capacitance Value ( $\mu$ F)/working voltage (V),

NP  $\rightarrow$  non-polar (or bipolar) electrolytic cap.

Refer to the parts list for additional component information.

$\odot$  indicates test point connection

$\perp$  indicates chassis ground unless otherwise specified

Hz indicates cycles per second

For **safety** purposes (and continuing reliability)

$\triangle$  replace all components marked with safety symbol with identical type.

NOTE: FR  $\rightarrow$  fusible resistor ( $\text{---}\text{---}$ )

00-4147-04  
 G07-CB0

Parts identification on circuit boards:

e.g. SU1126A (R107 = R1107)

SU3030A (R113 = R3113)

# REPLACEMENT PARTS LIST - ELECTROHOME 19" MONITOR

Components identified by the  $\Delta$  symbol in the PARTS LIST and on the Schematic have special characteristics important to safety.

DO NOT degrade the safety of the set through improper servicing.

## Abbreviations for Resistors and Capacitors

### Resistor

C R : Carbon Resistor  
Comp. R : Composition Resistor  
OM R : Oxide Metal Film Resistor  
V R : Variable Resistor  
MF R : Metal Film Resistor  
CMF R : Coating Metal Film Resistor  
UNF R : Nonflammable Resistor  
F R : Fusible Resistor

### Capacitor

C Cap. : Ceramic Capacitor  
M Cap : Mylar Capacitor  
E Cap. : Electrolytic Capacitor  
BP E Cap. : Bi-Polar (or Non-Polar) Electrolytic Capacitor  
MM Cap. : Metalized Mylar Capacitor  
PP Cap. : Polypropylene Capacitor  
MPP Cap. : Metalized PP Capacitor  
PS Cap : Polystyrol Capacitor  
Tan. Cap. : Tantal Capacitor

NOTE: When ordering replacement parts please specify the part number as shown in this list including part name, and model number. Complete information will help expedite the order.

Use of substitute replacement parts which do not have the same safety characteristics as specified, may create shock, fire or other hazards. For maximum reliability and performance, all parts should be replaced by those having identical specifications.

## SERVICE REPLACEMENT PARTS LIST

Symbol	Description	Part Number
	Main P.C.B. Ass'y	SU-1133A
	CRT Socket P.C.B. Ass'y	SU-3032A
	Purity Shield Ass'y	07-220083-03

## Outside of the P.C.B. Ass'y

Symbol	Description	Part Number
△	Picture Tube 19"	17-7198-03
△	△Deflection Yoke	A29779-D = 21-141-01
△	PC Magnet	A75034-B = 29-32-01
△	△Flyback Transf.	A29951-B
△	△HVR	A46600-A
R05	UNF Resistor 220Ω, 25W K	QRF258K-221
C04	C Capacitor 150pF, AC1.5KV	QCZ0101-005
X01	Si. Transistor	2SD870
X02	Si. Transistor	2SC1106A
SC	Screw #8-3/8	31-610818-06
SC	Screw 1/4 x 3/4 Pix Tube Mtg. (4)	31-601418-12
WA	Pyramidal Lock Washer (4)	33-255-01
	Nut Retainer, Pix Tube Mtg. (4)	33-494-01
	Clip — P.C.B. Support	33-629-02
	Standoff	33-670-010R-02
	Wire Terminal (Gnd. Strap)	34-228-03
	Terminal Lug (Gnd.)	34-33-04
	Groundstrap Assy.	34-574-02
	Grounding Spring	35-212-03
	Wire Hook (Gnd. Strap)	35-3053-02
	Purity Shield Holddown Clamp	35-2348-01
	Support Brkt. RH	35-3890-01
	Support Brkt. LH	35-3890-02
	Chassis Base	38-449-02
	Yoke Wedge (3)	39-1233-01

## Purity Shield Ass'y. Parts List

Symbol	Description	Part Number
D911, D912	Degaussing Coil	21-1007-30
	Rectifier 1 Amp 600V (2)	28-22-27
	Pin Terminal (2)	34-708-01
	Pin Terminal Housing	34-709-01
	Purity Shield (2 pcs.)	35-3847-01
	Purity Shield (2 pcs.)	35-3847-02
C911	Capacitor 100nF 10% 400V	48-171544-62
R921	Resistor, Wirewound 33Ω, 4W	42-113301-03
	Fire Retardent Term. Strip 4 Lug	34-492-09

## CRT Socket P.C.B. Ass'y (SU-3032A) Parts List

### Resistors

Symbol	Description	Part Number
R3105	V R 200	QVZ3234-022
R3106	V R 200	QVZ3234-022
R3113	V R 5K	QVZ3234-053
R3114	V R 5K	QVZ3234-053
R3115	V R 5K	QVZ3234-053
R3116	OM R 10KΩ2W J	QRG029J-103
R3117	OM R 10KΩ2W J	QRG029J-103
R3118	OM R 10KΩ2W J	QRG029J-103
R3119	Comp. R 3.3KΩ1/2W K	QRZ0039-332
R3120	Comp. R 3.3KΩ1/2W K	QRZ0039-332
C3121	Comp. R 3.3KΩ1/2W K	QRZ0039-332

### Capacitors

Symbol	Description	Part Number
C3107	E Cap. 10uF 250V A	QEW53EA-106
C3108	C Cap. 1000pF DC1400V P	QCZ9001-102M

### Coils

Symbol	Description	Part Number
L3101	Peaking Coil	QLL043K-101

**Semiconductors****Symbol**X3101  
X3102  
X3103**Description**Si. Transistor  
Si. Transistor  
Si. Transistor**Part Number**2SC1514VC  
2SC1514VC  
2SC1514VC**Miscellaneous****Symbol**

△

**Description**

△CRT Socket

**Part Number**

A76068

**Main PCB Ass'y (SU-1133A) Parts List****Resistors****Symbol**R1406  
R1408  
R1410  
R1414  
R1415  
R1421  
R1422  
△FR1401  
△R1503  
R1504  
R1509  
R1512  
R1514  
R1515  
R1522  
R1523  
R1528  
R1534  
VR1501  
△R1703  
△R1704  
△R1901  
R1902  
R1903  
R1904  
R1905  
△Q1908  
△R1909  
R1910  
△FR1901**Description**V R 200Ω  
V R 200Ω  
CMF R 6.8Ω1W J  
OM R 3.3KΩ1W J  
OM R 2.7KΩ1W J  
OM R 12KΩ2W J  
V R 10KΩ  
△F R 68Ω24K-680M  
△CMF R 11.8KΩ¼W +1%  
V R 5KΩ  
OM R 10KΩ2W J  
OM R 8.2KΩ2W J  
OM R 820Ω2W J  
CMF R 8.2Ω1W J  
CMF R 4.7Ω1W J  
OM R 68Ω2W J  
OM R 390Ω1W J  
ZN R  
ZN R  
△CMF R 39Ω½W +1%  
△CMF R 7.68KΩ¼W +1%  
△Posistor  
UNF R 2Ω7W K  
CMF R 4.7Ω3W J  
OM R 10KΩ2W J  
OM R 18KΩ1W J  
△CMF R 47Ω½W +1%  
V R 2KΩ  
△CMF R 2.74KΩ¼W +1%  
△F R 220Ω½W K**Part Number**QVZ3230-002  
QVZ3230-002  
QRX019J-6R8  
QRG019J-332  
QRG019J-272  
QRG026J-123Z  
QVZ3230-014  
QRH024K-680M  
QRV142F-1182  
QVZ3230-053  
QRG026J-103Z  
QRG026J-822Z  
QRG026J-821Z  
QRX019J-8R2  
QRX019J-4R7  
QRG026J-680Z  
QRG019J-391  
ERZ-C05ZK471  
ERZ-C05DK271  
QRV122F-3902  
QRV142F-7681  
A75414  
QRF076K-2R0  
QRX039J-4R7  
QRG026J-103Z  
QRG019J-183  
QRV122F-470Z  
QVP5A0B-023E  
QRV142F-2741  
QRH124K-221M**Capacitors****Symbol**C1301  
C1402  
C1407  
C1411  
C1412  
C1508  
△C1512  
△C1513  
△C1514  
C1515  
C1520  
C1523  
C1524  
△C1531  
△C1532  
C1904  
C1905**Description**BPE Cap. 3.3uF 50V A  
Tan. Cap. 2.2uF 16V K  
E Cap. 4.7uF 6.3V A  
E Cap. 100uF 160V A  
E Cap. 3.3uF 160V A  
PP Cap. 5600uF 50V J  
△PP Cap. 2000pF DC1500V J  
△PP Cap. 2000pF DC1500V J  
△PP Cap. 2000pF DC1500V J  
PP Cap. 0.53uF DC1200V J  
BPE Cap. 3.3uF 50V A  
E Cap. 1uF 160V A  
M Cap. 0.1uF 200V K  
△PP Cap. 2000pF DC1500V J  
△PP Cap. 1500pF DC1500V J  
E Cap.  
E Cap. 10uF 250V A**Part Number**QEN61HA-335Z  
QEE51CK-225B  
QEW51JA-475  
QEW52CA-107  
QEW52CA-335  
QFP31HJ-562  
QFZ0082-202  
QFZ0082-202  
QFZ0082-202  
QFZ0067-534  
QEN61HA-335Z  
QEW62CA-105Z  
QFM720K-104M  
QFZ0082-202  
QFZ0082-152  
QEY0034-001  
QEW52EA-106

<b>Colls</b>	<b>Description</b>	<b>Part Number</b>
<b>Symbol</b>		
L1502	Linarity Coil	A39835
L1503	Width Coil	C30380-A
L1504	Heater Choke	C30445-A
<b>Transformers</b>		
<b>Symbol</b>	<b>Description</b>	<b>Part Number</b>
T1501	Hor. Drive Transf.	A46022-BM
T1503	Side Pin Transf.	C39050-A
<b>Semiconductors</b>		
<b>Symbol</b>	<b>Description</b>	<b>Part Number</b>
IC1501	IC	HA11244
X1101	Si. Transistor	2SC1685(R)
X1102	Si. Transistor	2SA673(C)
X1103	Si. Transistor	2SC1685(R)
X1104	Si. Transistor	2SA673(C)
X1105	Si. Transistor	2SC1685(R)
X1106	Si. Transistor	2SA673(C)
X1301	Si. Transistor	2SC1685(R)
X1302	Si. Transistor	2SC1685(R)
X1303	Si. Transistor	2SA673(C)
X1304	Si. Transistor	2SC1685(R)
X1305	Si. Transistor	2SC1685(R)
X1401	Si. Transistor	2SD478
X1402	Si. Transistor	2SD478
X1501	Si. Transistor	2SC2610BK
X1901	Si. Transistor	2SC2688 (K.L.M.)
X1902	Si. Transistor	2SC1890A (E.F.)
D1101	Si. Diode	W06A
D1102	Si. Diode	W06A
D1103	Si. Diode	W06A
D1301	Si. Diode	1SZ473H
D1401	Si. Diode	1SZ473H
D1402	Zener Diode	RD10F(C)
D1503	Si. Diode	HF-1
D1504	Si. Diode	V09E
D1505	Zener Diode	RD11E(B)
D1506	Si. Diode	W06A
D1507	Si. Diode	1SS81
D1508	Si. Diode	1SZ473H
△D1701	△Zener Diode	RD20EV2
△D1901	△Si. Diode	1S1887A
△D1902	△Si. Diode	1S1887A
△D1903	△Si. Diode	1S1887A
△D1904	△Si. Diode	1S1887A
△D1905	△Zener Diode	RD6.8EV3
<b>Miscellaneous</b>		
<b>Symbol</b>	<b>Description</b>	<b>Part Number</b>
△F1901	△Fuse 1.25A	QMF53U1-1R25S
△F1902	△UL Fuse 3A	QMF66U1-3R0S

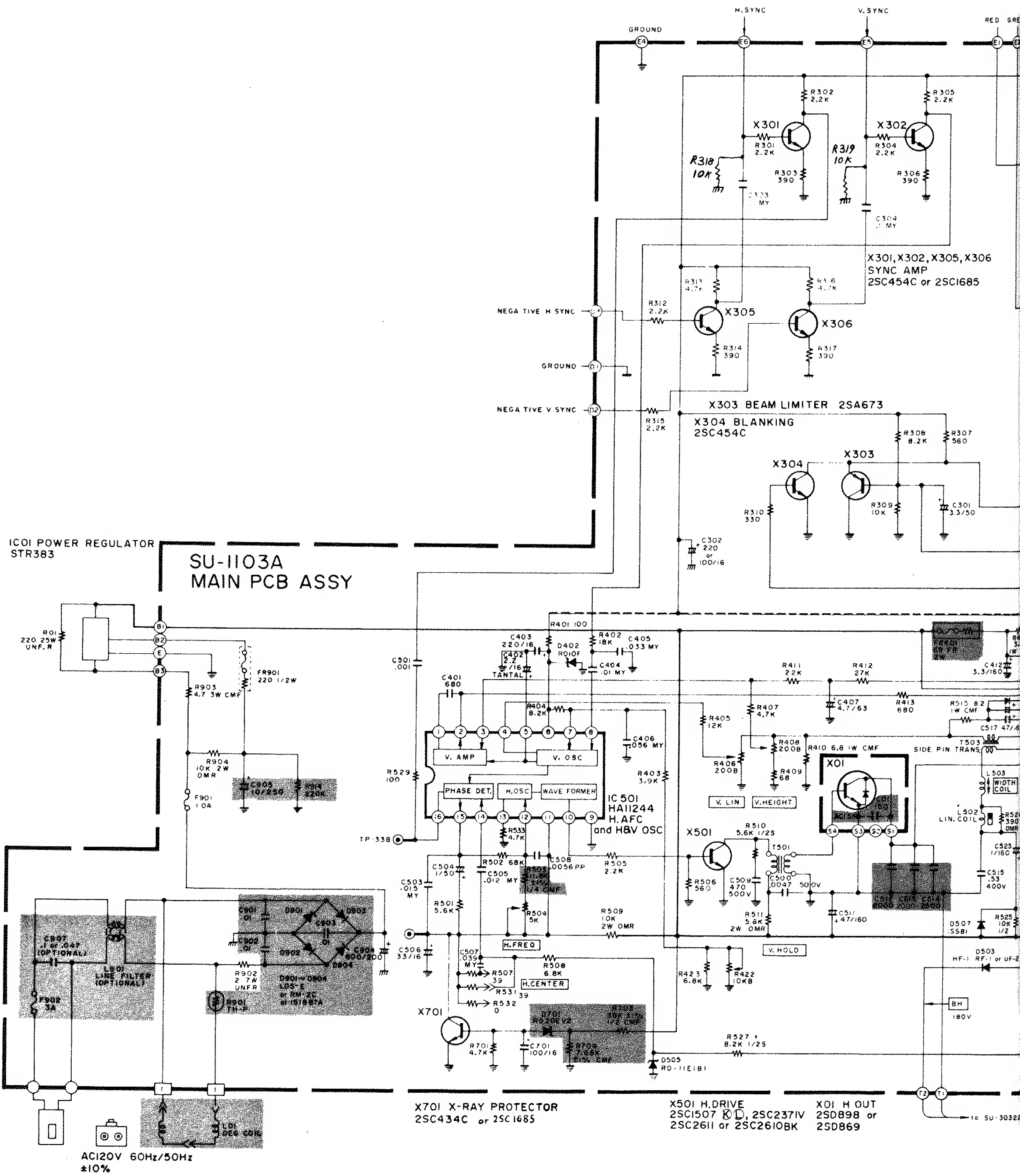

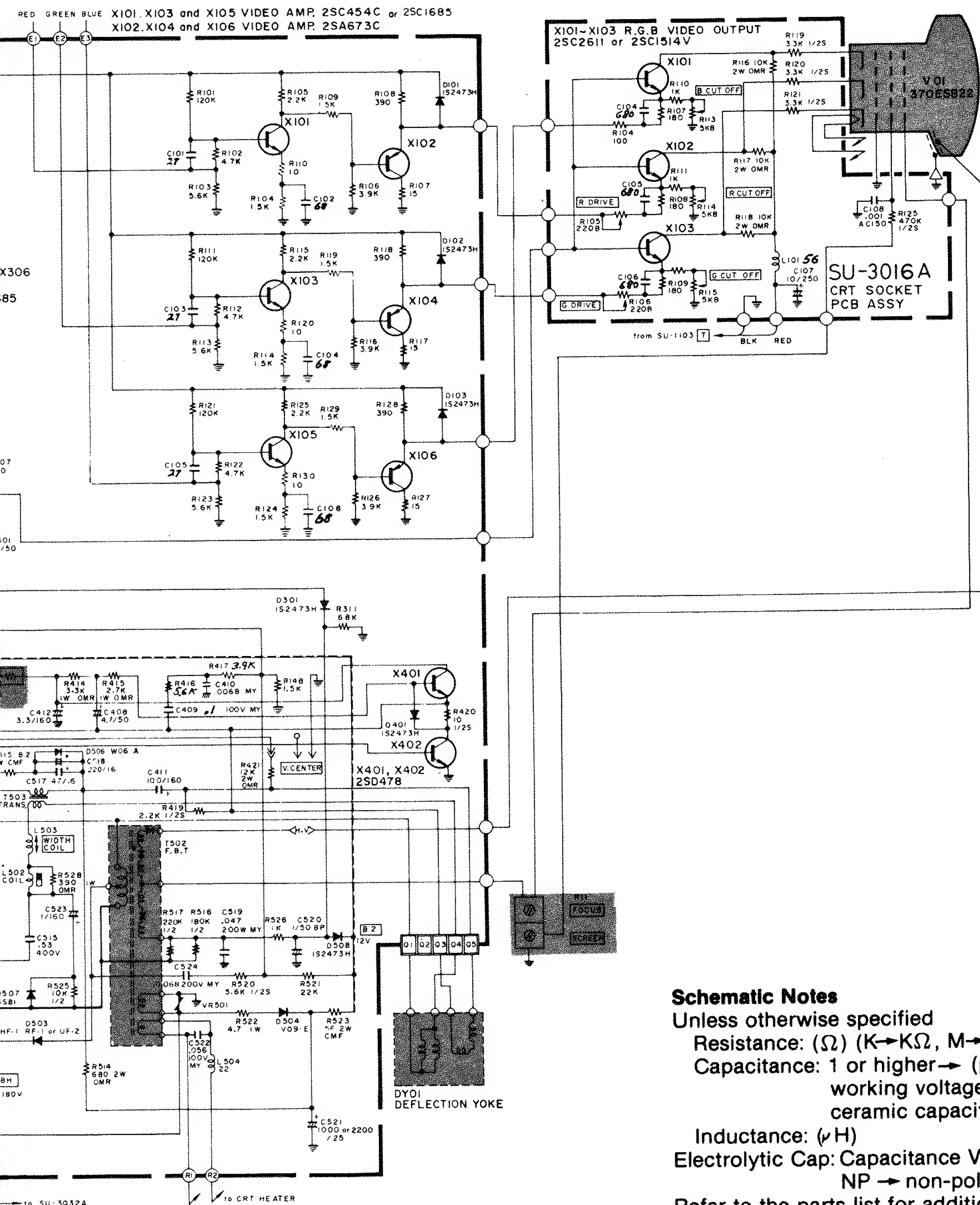

**Schematic Notes**

Unless otherwise specified

Resistance: ( $\Omega$ ) (K $\rightarrow$ K $\Omega$ , M $\rightarrow$ M $\Omega$ ), 1/4 (W) carbon resistor  
 Capacitance: 1 or higher  $\rightarrow$  (pF), less than 1  $\rightarrow$  ( $\mu$ F)  
 working voltage  $\rightarrow$  50 (V)  
 ceramic capacitor

Inductance: ( $\mu$ H)

Electrolytic Cap: Capacitance Value ( $\mu$ F)/working voltage (V),  
 NP  $\rightarrow$  non-polar (or bipolar) electrolytic cap.

Refer to the parts list for additional component information.

$\odot$  indicates test point connection

$\perp$  indicates chassis ground unless otherwise specified

Hz indicates cycles per second

For **safety** purposes (and continuing reliability)

$\triangle$  replace all components marked with safety symbol with identical type.

NOTE: FR  $\rightarrow$  fusible resistor ( $\text{---}\text{---}$ )

G07-FBO  
 00-4147-03

Parts identification on circuit boards:  
 e.g. SU1126A (R107 = R1107)  
 SU3030A (R113 = R3113)



# REPLACEMENT PARTS LIST - ELECTROHOME 13" MONITOR

Components identified by the  $\Delta$  symbol in the PARTS LIST and on the Schematic have special characteristics important to safety.

DO NOT degrade the safety of the set through improper servicing.

## Abbreviations for Resistors and Capacitors

### Resistor

C R	: Carbon Resistor
Comp. R	: Composition Resistor
OM R	: Oxide Metal Film Resistor
V R	: Variable Resistor
MF R	: Metal Film Resistor
CMF R	: Coating Metal Film Resistor
UNF R	: Nonflammable Resistor
F R	: Fusible Resistor

### Capacitor

C Cap.	: Ceramic Capacitor
M Cap	: Mylar Capacitor
E Cap.	: Electrolytic Capacitor
BP E Cap.	: Bi-Polar (or Non-Polar) Electrolytic Capacitor
MM Cap.	: Metalized Mylar Capacitor
PP Cap.	: Polypropylene Capacitor
MPP Cap.	: Metalized PP Capacitor
PS Cap	: Polystyrol Capacitor
Tan. Cap.	: Tantal Capacitor

NOTE: When ordering replacement parts please specify the part number as shown in this list including part name, and model number. Complete information will help expedite the order.

Use of substitute replacement parts which do not have the same safety characteristics as specified, may create shock, fire or other hazards. For maximum reliability and performance, all parts should be replaced by those having identical specifications.

Symbol	Description	Part Number
	Main P.C.B. Ass'y	SU-1103A
	CRT Socket P.C.B. Ass'y	SU-3016A

### Outside of the P.C.B. Ass'y

Symbol	Description	Part Number
$\Delta$ V01	$\Delta$ Picture Tube	370ESB22(E)
$\Delta$ DY01	$\Delta$ Deflection Yoke	C29123-V
	PC Magnet	A76366-A
	Wedge	C30006
	$\Delta$ Flyback Transf.	A19183-A
$\Delta$ R11	$\Delta$ Focus V R	A46606-A
$\Delta$ R05	UNF Resistor 220 $\Omega$ , 25W. K	QRF258K-221
$\Delta$ C04	$\Delta$ C Capacitor 150 pF, AC1.5KV	QCZ0101-005
X01	Si. Transistor	2SD869
IC01	IC Regulator	STR383
L01	Degaussing Coil	21-1007-31
	Degaussing Coil Pin Terminal (2)	34-708-01
	Degaussing Coil Pin Terminal Housing	34-709-01
	Groundstrap Ass'y.	34-697-04
	Groundstrap Wire Terminal	34-228-03
	Groundstrap Spring (2)	35-3560-01
BR	Support Bracket RH	35-3919-01
BR	Support Bracket LH	35-3919-02
SC	SCREW 10- $\frac{1}{2}$ Pix Tube Mtg. (4)	31-631018-08
WA	Pyramidal Lockwasher (4)	33-255-01
	Clip P.C.B. Support (2)	33-629-02
	Ground Lug	34-33-04
CH	Chassis Base	38-452-01

# Main P.C.B. Ass'y (SU-1103A) Parts List

Resistors		
Symbol	Description	Part Number
R1406	V R 200Ω	QVZ3230-022
R1408	V R 200Ω	QVZ3230-022
R1410	CMF R 6.8Ω1W J	QRX019J-6R8
R1414	OM R 3.3KΩ1W J	QRG019J-332
R1415	OM R 2.7KΩ1W J	QRG019J-272
R1421	OM R 12KΩ2W J	QRG029J-123
R1422	V R 10KΩ	QVZ3224-014H
△FR1401	△F R 68Ω2W K	QRH024K-680M
△R1503	△CMF R 11.8KΩ¼W +1%	QRV142F-1182
R1504	V R 5KΩ	QVZ3230-053
R1509	OM R 10KΩ2W J	QRG029J-103
R1511	OM R 5.6KΩ2W J	QRG029J-562
R1514	OM R 680Ω2W J	QRG029J-681
R1515	CMF R 8.2Ω1W J	QRX019J-8R2
R1522	CMF R 4.7Ω1W J	QRX019J-4R7
R1523	OM R 56Ω2W J	ORG029J-560
R1528	OM R 390Ω1W J	ORG019J-391
R1534	ZN R	ERZ-C05ZK471
VR1501	ZN R	ERZ-C05DK271
△R1703	△CMF R 39KΩ½W +1%	QRV122F-3902
△R1704	△CMF R 7.68KΩ¼W +1%	QRV142F-7681
△R1901	△Posistor	A75414
R1902	UNF R 2Ω7W K	QRF076K-2R0
R1903	CMF R 5.6Ω3W J	QRX039J-5R6
R1904	OM R 10KΩ2W J	QRG026J-103Z
△FR1901	△F R 220Ω½W K	QRH124K-221M
Capacitors		
Symbol	Description	Part Number
C1402	Tan. Cap. 2.2uF 16V K	QEE51CK-225B
C1411	E Cap. 100uF 160V A	QEW52CA-107
C1412	E Cap. 3.3uF 160V A	QEW52CA-335
C1508	PP Cap. 5600pF 50V J	QFP31HJ-562
C1511	E Cap. 47uF 160V A	QEW52CA-476S
△C1512	△PP Cap. 2000pF DC1500V J	QFZ0082-202
△C1513	△PP Cap. 2000pF DC1500V J	QFZ0082-202
△C1514	△PP Cap. 2500pF DC1500V J	QFZ0082-252
C1515	PP Cap. 0.53uF DC1200V K	QFZ0067-534
C1520	BPE Cap. 1uF 50V A	QEN61HA-105Z
C1524	M Cap. 0.1uF 200V K	QFM72DK-682M
C1904	E Cap.	QEY0034-001
C1905	E Cap. 10uF 250V A	QEW52EA-106
△C1907	△MM Cap. 0.1uF AC150V Z	QFZ9008-104
Colls		
Symbol	Description	Part Number
L1501	Peaking Coil	A75360-6
L1502	Liniarty Coil	A39934
L1503	Width Coil	C30380-A
L1504	Heater Choke	C30333-A
L1901	Line Filter	A39475-J
Transformers		
Symbol	Description	Part Number
T1501	Hor. Drive Transf.	A46022-BM
T1503	Side Pin Transf.	C39050-A

<b>Semiconductors</b>		
<b>Symbol</b>	<b>Description</b>	<b>Part Number</b>
IC1501	I.C.	HA11244
X1101	Si. Transistor	2SC1685(R)
X1102	Si. Transistor	2SA673(C)
X1103	Si. Transistor	2SC1685(R)
X1104	Si. Transistor	2SA673(C)
X1105	Si. Transistor	2SC1685(R)
X1106	Si. Transistor	2SA673(C)
X1301	Si. Transistor	2SC1685(R)
X1302	Si. Transistor	2SC1685(R)
X1303	Si. Transistor	2SA673(C)
X1304	Si. Transistor	2SC1685(R)
X1305	Si. Transistor	2SC1685(R)
X1401	Si. Transistor	2SD478
X1402	Si. Transistor	2SD478
X1501	Si. Transistor	2SC2610BK
X1701	Si. Transistor	2SC1685(P-S)
D1101	Si. Diode	W06A
D1102	Si. Diode	W06A
D1103	Si. Diode	W06A
D1301	Si. Diode	1S2473H
D1401	Si. Diode	1S2473H
D1402	Zener Diode	RD10F(C)
D1503	Si. Diode	HF-1
D1504	Si. Diode	V09E
D1505	Zener Diode	RD11E(B)
D1506	Si. Diode	W06A
D1507	Si. Diode	1SS81
D1508	Si. Diode	1S2473H
△D1701	△Zener Diode	RD20EV2
△D1901	△Si. Diode	1S1887A
△D1902	△Si. Diode	1S1887A
△D1903	△Si. Diode	1S1887A
△D1904	△Si. Diode	1S1887A
<b>Miscellaneous</b>		
<b>Symbol</b>	<b>Description</b>	<b>Part Number</b>
△F1901	△Fuse 1A	QMF53U1-1R0S
△F1902	△UL Fuse 3A	QMF66U1-3R0S

## CRT Socket P.C.B. Ass'y (SU-3016A) Parts List

### Resistors

Symbol	Description	Part Number
R3105	V R 200Ω	QVZ3234-022
R3106	V R 200Ω	QVZ3234-022
R3113	V R 5KΩ	QVZ3234-053
R3114	V R 5KΩ	QVZ3234-053
R3115	V R 5KΩ	QVZ3234-053
R3116	OM R 10KΩ2W J	QRG029J-103
R3117	OM R 10KΩ2W J	QRG029J-103
R3118	OM R 10KΩ2W J	QRG029J-103
R3119	Comp. R 3.3KΩ½W K	QRZ0039-332
R3120	Comp. R 3.3KΩ½W K	QRZ0039-332
R3121	Comp. R 3.3KΩ½W K	QRZ0039-332

### Capacitors

Symbol	Description	Part Number
C3107	E Cap. 10uF 250V A	QEW52EA-106
C3108	C Cap. 1000pF DC1400V P	QCZ9001-102M

### Coils

Symbol	Description	Part Number
L3101	Peaking coil	QQL043K-101

### Semiconductors

Symbol	Description	Part Number
X3101	Si. Transistor	2SC2611
X3102	Si. Transistor	2SC2611
X3103	Si. Transistor	2SC2611

### Miscellaneous

Symbol	Description	Part Number
△	△ CRT Socket	A75522

## INSTRUCTIONS FOR MODIFICATION OF PAC-MAN GAME PCB

THE FOLLOWING ARE INSTRUCTIONS FOR MODIFYING PAC-MAN PCB SUCH THAT ① THE DEGREE OF DIFFICULTY OF THE GAME IS INCREASED.

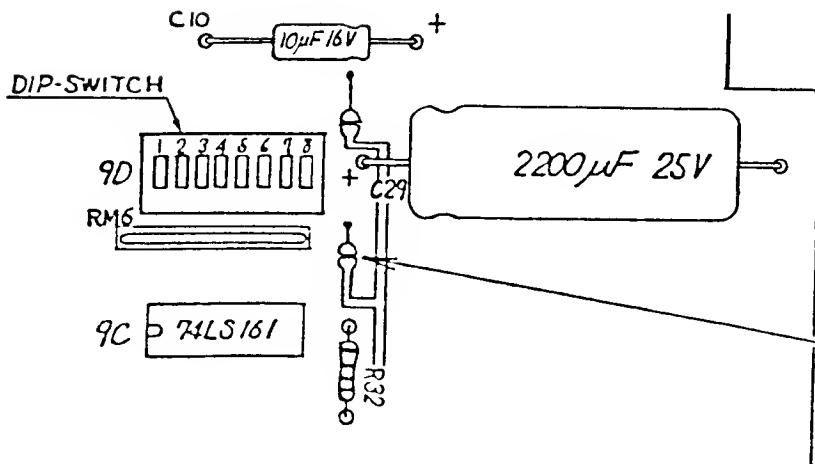
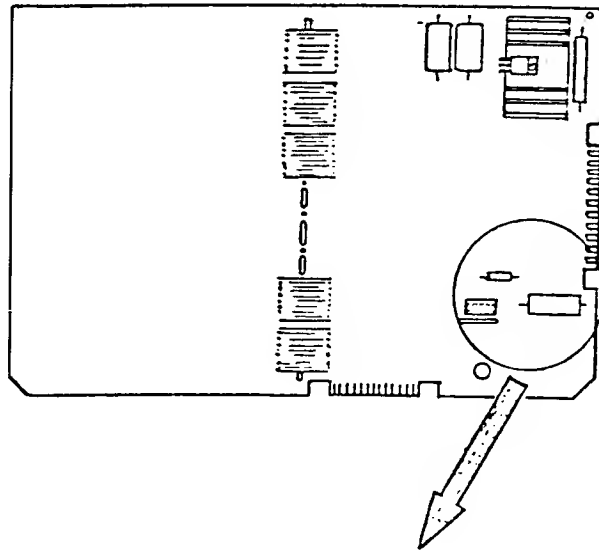

① When this jumper pad is connected, the game becomes more difficult.

**WARNING: THIS EQUIPMENT GENERATES, USES, AND CAN RADIATE RADIO FREQUENCY ENERGY AND IF NOT INSTALLED AND USED IN ACCORDANCE WITH THE INSTRUCTIONS MANUAL, MAY CAUSE INTERFERENCE TO RADIO COMMUNICATIONS. AS TEMPORARILY PERMITTED BY REGULATION IT HAS NOT BEEN TESTED FOR COMPLIANCE TO SUBPART J OR PART 15 OF FCC RULES, WHICH ARE DESIGNED TO PROVIDE REASONABLE PROTECTION AGAINST SUCH INTERFERENCE. OPERATION OF THIS EQUIPMENT IN A RESIDENTIAL AREA IS LIKELY TO CAUSE INTERFERENCE IN WHICH CASE THE USER AT HIS OWN EXPENSE WILL BE REQUIRED TO TAKE WHATEVER MEASURES MAY BE REQUIRED TO CORRECT THE INTERFERENCE.**

M051-00095-0000